

AUFBAUANLEITUNG „SmartBase“

- Ⓒ GB Assembly manual for “SmartBase”
- Ⓒ FR Notice de montage pour “SmartBase”
- Ⓒ NL Opbouwbeschrijving “SmartBase”
- Ⓒ ES Instrucciones de montaje “SmartBase”
- Ⓒ IT Istruzioni di montaggio “SmartBase”
- Ⓒ DK Monteringsvejledning for “SmartBase”
- Ⓒ SE Monteringsanvisning för “SmartBase”
- Ⓒ NO Monteringsveiledning for “SmartBase”
- Ⓒ PL Instrukcja montażu “SmartBase”
- Ⓒ SK Montážny návod pre “SmartBase”
- Ⓒ SI Priročnik za montažo “SmartBase”
- Ⓒ CZ Montážní manual pro “SmartBase”
- Ⓒ HU Felépítési útmutató “SmartBase”
- Ⓒ HR Priručnik za montažu za “SmartBase”



WICHTIGE PUNKTE FÜR DEN AUFBAU!



VORLIEGENDE AUFBAUANLEITUNG ZEIGT DEN ZUSAMMENBAU FÜR EIN "SMARTBASE" GRÖSSE „HIGHLINE®“ H3. DEN PLAN FÜR IHRE FUNDAMENTGRÖSSE FINDEN SIE AB SEITE 8. FÜR EINIGE MONTAGESCHRITTE BENÖTIGEN SIE EINEN HELFER.

- GB** Important details regarding assembly! This assembly manual shows the installation of the "SmartBase" for "HighLine®" size H3. You find the plan for your foundation size from page 8. For several assembly steps additional assistance of one person will be required.
- FR** Points importants lors du montage! Cette notice de montage décrit l'assemblage de „SmartBase“ pour un „HighLine®“ H3. Vous trouverez le plan pour les dimensions de votre fondation à partir de la page 8. Pour certaines étapes, demandez l'aide d'une personne.
- NL** Belangrijke punten voor de montage! Deze montage instructies hebben betrekking op de opbouw van het SmartBase voor een „Highline®“ H3. De plattegrond voor uw fundamentgrootte vindt u op pag. 8. Voor enkele montageschappen heeft u 1 persoon nodig om u te helpen.
- ES** Notas importantes para el montaje: en estas instrucciones se muestra el montaje de los „SmartBase“ de la caseta „HighLine®“ H3. A partir de la página 8 encontrará el plano correspondiente al tamaño de sus cimientos. Es recomendable realizar algunos pasos del montaje con la ayuda de otra persona.
- IT** Indicazioni importanti per il montaggio! Le seguenti istruzioni di montaggio mostrano l'assemblaggio della „SmartBase“ di ancoraggio a terra per un „HighLine®“ dalla misura H3. A partire dalla pagina 8 trovate il prospetto per le misure della vostra fondazione. Per alcune fasi del montaggio sarà necessario essere aiutati.
- DK** Vigtige punkter ved samling! Den følgende monteringsvejledning viser opbygningen af en „SmartBase“ med jordspyd til et „HighLine®“ H3. Opgivelserne om fundamentets dimensioner finder du fra side 8. Du får brug for en hjælper til dele af monteringsarbejdet.
- SE** Viktiga punkter för montering! Dessa monteringsanvisningar visar hur "SmartBase" för en "HighLine®" H3 monteras. Du hittar ritningen för ditt fundament på sidan 8 och framåt. Du behöver en medhjälpare för en del monteringssteg.
- NO** Viktige punkter for montering! Denne monteringshåndboken viser installasjonen av "SmartBase" for "HighLine®" -størrelse H3. Du finner planen for grunnstørrelsen din fra side 8. For flere monteringstrinn vil det være nødvendig med ytterligere hjelp fra en person.
- PL** Wskazówki dotyczące montażu. Niniejsza instrukcja wskazuje sposób montażu "SmartBase HighLine®" H3. Schematy dla innych wielkości od strony 8. Może być konieczna pomoc drugiej osoby.
- SK** Dôležité body pre montáž! Táto montážna príručka ukazuje inštaláciu základu „SmartBase“ pre „HighLine®“ H3. Plán veľkosti základu nájdete na strane 8. Pri niekoľkých montážnych krokoch bude potrebná pomoc ďalšej osoby.
- SI** Pomembne točke za montažo! Ta priročnik za montažo prikazuje namestitev "SmartBase" za velikost "HighLine®" H3. Načrt za vašo velikost temelja najdete na strani 8. Za več korakov sestavljanja bo potrebna dodatna pomoč ene osebe.
- CZ** Důležité body pro montáž! Tato montážní příručka ukazuje instalaci základu "SmartBase" pro "HighLine®" H3. Plán velikosti základu najdete na straně 8. U několika montážních kroků bude zapotřebí pomoc další osoby.
- HU** Fontos információk az összeszereléshez! Ez a szerelési útmutató a „SmartBase“, összeszerelését mutatja a „HighLine®“ H3 szerszámós ház esetén. Az alapzat-méretének a tervét, az 8. oldaltól találja meg. Néhány összeszerelési lépéshez 1 fő segítségére lesz szüksége.
- HR** Važne napomene za montažu! Ovaj priručnik za montažu prikazuje ugradnju „SmartBase vijka“ za veličinu „HighLine®“ H3. Plan za veličinu temelja potražite na stranici 8. Za nekoliko koraka montaže bit će potrebna dodatna pomoć jedne osobe.

VERWENDEN SIE BEI DER MONTAGE ARBEITSHANDSCHUHE! UM KRATZER ZU VERMEIDEN, VERWENDEN SIE BITTE GEEIGNETE UNTERLAGEN!

- GB** Wear working gloves! Please use a suitable underlay to avoid scratches!
- FR** Portez des gants de travail! Pour éviter les rayures, utilisez les supports appropriés!
- NL** Handschoenen gebruiken! Om krassen te voorkomen raden wij u aan er iets onder te leggen!
- ES** Utilice unos guantes de trabajo. Por favor, coloque en el suelo una base protectora adecuada para evitar posibles arañazos.
- IT** Utilizzare guanti da lavoro. Utilizzare una base adatta per evitare graffi!
- DK** Brug arbejdshandsker! Benyt venligst et passende underlag for at undgå skrammer!
- SE** Använd arbetshandskar under monteringen! Använd lämpliga underlag för att undvika repor!
- NO** Bruk arbeidshansker! Bruk et passende underlag for å unngå riper!
- PL** Podczas montażu proszę używać rękawice ochronne. Chronić powierzchnię lakierowaną przed zarysowaniami.
- SK** Používajte pracovné rukavice! Prosím, použite vhodnú podložku, aby ste zabránili poškrábaniu!
- SI** Uporabite delovne rokavice! Uporabite ustrezno podlago, da se izognete praskam!
- CZ** Při montáži používejte pracovní rukavice! Použijte vhodné podložky, abyste se vyhnuli poškrábání!
- HU** Szerelésnél használjon védőkesztyűt! A karcolások elkerülése érdekében használjon megfelelő alátétetket!
- HR** Nosite radne rukavice! Upotrijebite odgovarajuće podlago, da se izognete praskam!

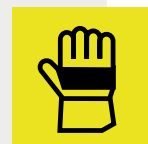

WASSERWAAGEN - SYMBOL!

Betreffendes Einbauteil mit der Wasserwaage ausrichten.

- GB** Symbol of spirit level: Align the respective parts by using the spirit level.
- FR** Symbole niveau à bulle: Lorsque ce symbole apparaît, vous devez ajuster l'élément à l'aide d'un niveau à bulle.
- NL** Waterpas – symbol: Bij montageschappen waar dit symbool bijstaat is het noodzakelijk het betreffende onderdeel waterpas in te bouwen.
- ES** Símbolo del nivelador: Indica que se debe ajustar y centrar la pieza con la ayuda de un nivelador.
- IT** Simbolo di livella a bolla d'aria: Allineare il componente in questione con l'ausilio di una livella a bolla d'aria.
- DK** Symbol for vaterpas: Juster de respektive dele ved hjælp af vaterpas.
- SE** Vattenpassymbol: Rikta in relevant installationsdel med vattenpasset.
- NO** Symbol på vater: Juster de respektive delene ved å bruke et vater.
- PL** Symbol poziomicy - element wypoziomować.
- SK** Symbol vodováhy: Vyrovnajte príslušnej časti pomocou vodováhy.
- SI** Simbol vodne tehtnice: Poravnajte ustrezne dele z uporabo vodne tehtnice.
- CZ** Symbol vodováhy: Vyrovnajte příslušné části pomocí vodováhy.
- HU** Vízmérték – szimbólum: A szükséges elem beállításához használjon vízmértéket.
- HR** Simbol libele: Poravnajte odgovarajuće dijelove pomoću libele.

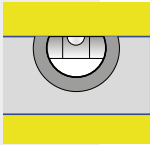

MASSTABSGETREUE ABBILDUNGEN DER ZU VERWENDENDEN SCHRAUBEN! (M 1:1)

- GB** Scale drawing 1:1 of the screws in use
- FR** Reproduction selon l'échelle 1:1.
- NL** Afbeelding : schaal 1:1 (ware grootte)
- ES** Reproducción a escala 1:1 de los tornillos que se utilizan para el montaje.
- IT** Immagine in scala delle viti da utilizzare!
- DK** Skala tegning af skruer er 1:1
- SE** Skalenliga ritningar av skruvarna som ska användas:
- NO** Måltegning 1: 1 av skruene som er i bruk
- PL** Skalowane ilustracje używanych śrub:
- SK** Mierka výkresu 1: 1 použitých skrutiek
- SI** Risba v merilu 1: 1 uporabljenih vijakov
- CZ** Měřitko výkresu 1: 1 použitých šroubů
- HU** A felhasználandó csavarok méretarányos ábrái:
- HR** Crtež veličine 1: 1 vijaka koji se koriste

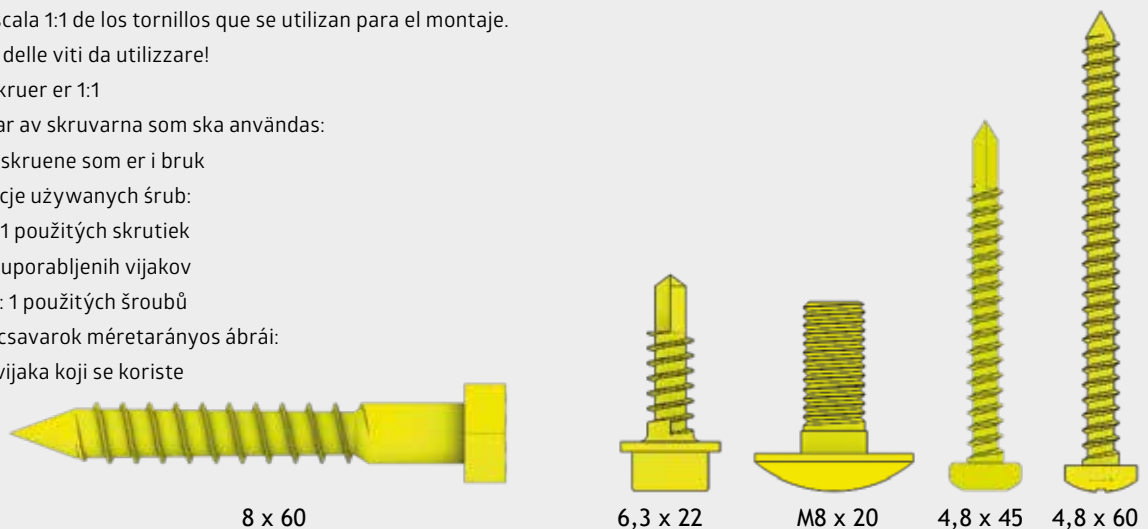

FOLGENDES WERKZEUG WIRD BENÖTIGT:

Akkuschrauber - Wasserwaage - Gabelschlüssel SW 24 und 13

- GB** Following tools are needed: Cordless screwdriver - Spirit level - Open end spanner SW 24 and 13
- FR** Outils supplémentaires requis: Visseuse sans fil - Niveau à bulle - Clé de 24 et 13
- NL** Volgend gereedschap heeft u nodig: Accuboormachine - Waterpas - Steeksleutel SW 24 en 13
- ES** Necesitará las herramientas siguientes: Atornillador con batería - Nivel de agua - Llaves de boca SW 24 y 13
- IT** Attrezzi necessari: Avvitatore elettrico - Vivella a bolla - Chiave fissa SW 24 e 13
- DK** Volgend gereedschap heeft u nodig: Akku-skruemaskine - Vaterpas - Gaffelnøgler, SW 24 og 13
- SE** Följande verktyg krävs: Sladdlös skruvmejsel - Vattenpass - Blocknyckel NV 24 och 13
- NO** Følgende verktøy er nødvendig: Skrutrekker - Vater - Åpne endenøkkel SW 24 og 13
- PL** Konieczne są następujące narzędzia: Wkrętarka akumulatorowa - Poziomica - Klucz płaski 24 i 13
- SK** Je potrebné nasledujúce náčinie: Akumulátorový skrutkovač - Vodováha - Vidlicový kľúč SW 24 a 13
- SI** Potrebna so naslednja orodja: Akumulatorski izvijač - Libelo - Ključ z odprtim koncem SW 24 in 13
- CZ** Je zapotřebí následující náčiní: Akumulátorový šroubovák - Vodováha - Vidlicový klič SW 24 a 13
- HU** Következő szerszámokra lesz szükség: Akkus csavarhúzó - Vízmérték - SW 24 és 13 villáskulcs
- HR** Potrebni su sljedeći alati: Akumulatorski odvijač - Raspoloženje - Otvoreni ključni ključ SW 24 i 13

HALTEN SIE WÄHREND DES ZUSAMMENBAUS ALLE MITGELIEFERTEN KLEINTEILE ODER VERPACKUNGSMATERIALIEN FERN VON KLEINKINDERN!

Bauteile weisen scharfe Kanten auf oder stehen vor, achten Sie während der Montage und bei der täglichen Nutzung darauf.

- (GB)** Keep all supplied small parts or packaging materials away from small children during assembly. Components have sharp edges or protrude, pay attention to them during assembly and during daily use.
- (FR)** Gardez toutes les petites pièces ou les matériaux d'emballage fournis hors de portée des enfants pendant le montage. Les pièces d'assemblage peuvent être tranchantes, faites-y attention lors de l'assemblage et de l'utilisation quotidienne.
- (NL)** Houd alle kleine onderdelen of verpakkingsmaterialen die worden mee geleverd uit de buurt van kleine kinderen tijdens de montage. Onderdelen hebben scherpe randen of steken uit, let op bij de montage en bij het dagelijks gebruik.
- (ES)** Mantenga todas las piezas pequeñas o materiales de embalaje suministrados lejos de los niños durante el montaje. Los componentes tienen bordes afilados o salientes, preste atención a ellos durante el montaje y durante el uso diario.
- (IT)** Tenere tutte le piccole parti o i materiali d'imballaggio forniti lontano dalla portata dei bambini durante il montaggio. I componenti hanno spigoli vivi o sporgenti, prestare attenzione ad essi durante il montaggio e durante l'uso quotidiano.
- (DK)** Hold alle leverede smådele og emballage utilgængeligt for børn under montagen. Komponenter har skarpe kanter eller stikker ud, vær opmærksom på dem under montering og under daglig brug.
- (SE)** Håll alla medföljande smådelar och förpackningsmaterial borta från småbarn under monteringen. Komponenterna kan ha vassa kanter eller utstickande delar, var uppmärksam på detta vid montering och daglig användning.
- (NO)** OBS: Hold alle smådeler og emballasjemateriale borte fra små barn under montering. Komponentene har skarpe kanter eller noe som stikker ut, vær oppmerksom på dette under monteringen og under den daglig bruken.
- (PL)** ZACHOWAJ WSZYSTKIE MAŁE CZĘŚCI PODCZAS MONTAŻU LUB MATERIAŁY OPAKOWANIA Z DALA OD MAŁYCH DZIECI. Elementy mają ostre lub wystające krawędzie, należy zwracać na to uwagę podczas montażu i codziennego użytkowania.
- (SK)** Udržujte počas montáže všetky dodané malé diely a obalové materiály mimo dosahu malých detí. Komponenty majú ostré hrany alebo vyčnievajúce časti. Dbajte na to počas montáže a každodenného používania.
- (SI)** POZOR: Med montažo naj bodo vsi dobavljeni majhni deli ali embalažni materiali oddaljeni od majhnih otrok. Sestavni deli imajo ostre robove ali pa štrlijo, bodite pozorni nanje med sestavljanjem in med vsakodnevno uporabo.
- (CZ)** Během montáže udržujte všechny malé dodávané díly nebo obalové materiály mimo dosah malých dětí. Díly mají ostré hrany nebo vyčnávají, věnujte jim pozornost při montáži a každodenním používání, aby nedošlo k úrazu.
- (HU)** Az összeszerelés során kigyerekeltől tartsa távol az apró alkatrészeket valamint a csomagolóanyagokat. A szerelés és a napi használat során ügyeljen az éles szélekre valamint a kiálló részekre.
- (HR)** PAŽNJA: Tijekom montaže držite sve isporučene male dijelove ili materijale za pakiranje podalje od male djece. Sastavni dijelovi imaju oštre rubove ili strše, obratite pažnju na njih tijekom montaže i tijekom svakodnevnog uporabe.

UMGANG MIT BESCHÄDIGTEN TEILEN!

Verbauen Sie keine beschädigten Teile! Falls Sie Beschädigungen feststellen, müssen diese vorab inkl. aussagekräftiger Bilder an uns gemeldet werden. Durch den Verbau gelten die Teile als akzeptiert.

- (GB)** Handling of damaged parts: Do not install damaged parts! If you note damages, they must be reported to us in advance, including meaningful pictures. The parts are considered accepted by the installation.
- (FR)** Manipulation des pièces endommagées: N'installez pas de pièces endommagées! Si vous découvrez des dommages, vous devez nous en informer à l'avance, en nous envoyant des photos significatives. Après le montage, les pièces sont considérées comme acceptées.
- (NL)** Omgaan met beschadigde onderdelen: Monteer géén beschadigde onderdelen! Als u schade ontdekt, moet dit vooraf aan ons worden gemeld, inclusief duidelijke foto's. Als u de beschadigde onderdelen toch monteert, dan heeft u hiermee het product "geaccepteerd".
- (ES)** Manejo de partes dañadas: Por favor, NO instale partes dañadas, Si descubre algún daño, debe informarnos con antelación, incluyendo fotos claras de los daños. Las piezas se consideran aceptadas si se realiza su la instalación.
- (IT)** Gestione di parti danneggiate: Non installare parti danneggiate! Se si rivela un danno, questo deve essere segnalato in anticipo per mail con materiale fotografico a supporto del reclamo. Se si procede all'installazione delle parti danneggiate, Biohort si riserva il diritto di respingere il reclamo.
- (DK)** Håndtering af beskadigede dele: Brug ikke beskadigede dele! Hvis du opdager nogen skade, skal dette rapporteres til os på forhånd, herunder meningsfulde billeder. Dele betragtes som accepteret gennem installationen.
- (SE)** Hantering av skadade delar: Använd inte skadade delar! Om du upptäcker några skador måste detta rapporteras till oss i förväg, inklusive meningsfulla bilder. Delarna anses accepterade när de installeras.
- (NO)** Håndtering av ødelagte deler: Ikke monter ødelagte deler! Hvis du registrerer skader, må du rapportere dette til oss, og sende bilder av de skadde delene. Hvis skadde deler blir montert, anses de som akseptert av montøren.
- (PL)** POSTĘPOWANIE Z USZKODZONYMI CZĘŚCIAMI Nie używaj uszkodzonych części! W przypadku stwierdzenia jakichkolwiek uszkodzeń należy je zgłosić wraz ze szczegółowymi zdjęciami. Elementy uszkodzone zainstalowane uważane są za zaakceptowane.
- (SK)** Zaochádzanie s poškodenými dielmi: V prípade že zistíte nejaké poškodenia, musia nám byť tieto nahlásené aj s príslušnými fotografiami. V prípade zabudovania budú diely považované za akceptované.
- (SI)** Ravnanje s poškodovanimi deli: Poškodovanih delov ne nameščajte! Če opazite škodo, nam je to treba sporočiti vnaprej, vključno s slikami. Nameštitev šteje, kot da so deli sprejeti.
- (CZ)** Manipulace s poškozenými částmi: Pokud zjistíte poškození, musíte nám to nahlásit předem, včetně průkazných obrázků. Díly jsou považovány za přijaté jejich instalací.
- (HU)** A sérült alkatrészek kezelése: Ha bármilyen sérülést észlel, a sérült elemeket képekel igazolva jeleni kell felénk. A beépítéssel, az elemeket elfogadottnak tekintjük.
- (HR)** Rukovanje oštećenim dijelovima: Nemojte postavljati oštećene dijelove! Ako primijetite štetu, morate nam je prijaviti unaprijed, uključujući značajne slike. Instalacija smatra da su dijelovi prihvaćeni.

FÜR DIE MONTAGE WERDEN MINDESTENS 50 CM PLATZ RUND UM DAS FUNDAMENT BENÖTIGT!

- (GB)** At least 50 cm space around the foundation is required for installation.
- (FR)** Un espace d'au moins 50 cm autour de la fondation est nécessaire pour le montage.
- (NL)** Voor de montage is ten minste 50 cm ruimte rond de fundering nodig.
- (ES)** Se requiere un espacio de al menos 50 cm alrededor de los cimientos para su instalación.
- (IT)** Per l'installazione sono necessari almeno 50 cm di spazio intorno alla fondazione.
- (DK)** For montage kræves yderligere 50cm plads omkring fundamentet.
- (SE)** Cirka 50 cm utrymme runt fundamentet krävs för montering.
- (NO)** For montering trenger du ca 50 cm plass rundt fundamentet.
- (PL)** Do instalacji potrzeba około 50 cm przestrzeni wokół fundamentu.
- (SK)** Pre inštaláciu je potrebné 50 cm okolo miesta okolo základne.
- (SI)** Morda izvedite preizkusno vrtnanje. Za montažo potrebujete približno 50 cm prostora okoli temeljev.
- (CZ)** Pro instalaci je třeba 50 cm okolo místa kolem základny.
- (HU)** Az összeszereléshez kb. 50 cm helyre van szükség az alap körül.
- (HR)** Možda provesti probnu vježbu. Za montažu trebate oko 50 cm prostora oko temelja.

DIE AUF DEN PLÄNEN ROT MARKIERTEN STELFÜSSE SIND IMMER MITTIG IM (GEWÄHLTEN) TÜRBEREICH ZU SETZEN!

- (GB)** The adjustable feet marked in red on the plans must always be placed in the middle of the (selected) door area!
- (FR)** Les pieds réglables marqués en rouge sur les plans doivent toujours être placés au centre de la zone de la porte (choisie)!
- (NL)** De rood gemarkeerde stelvoeten op de plattegronden moeten altijd centraal in het (geselecteerde) deurbereik worden geplaatst!
- (ES)** Los pies niveladores marcados en rojo en los planos deben estar siempre en el centro de la zona de la puerta (seleccionada)!
- (IT)** I piedini di livellamento contrassegnati in rosso devono essere sempre posizionati centralmente nella zona della porta!
- (DK)** De justerbare fødder, der er markeret med rødt på planerne, skal altid placeres midt i det (valgte) dørråde!
- (SE)** De justerbara fötterna markerade med rött på planerna måste alltid placeras i mitten av det (utvalda) dörrådet!
- (NO)** De justerbare føttene merket med rødt på planene må alltid plasseres midt i (valgt) dørråde!
- (PL)** Stopy fundamentowe oznaczone na czerwono na planach wiercenia zawsze umieszczaj na środku (wybranej) strefy drzwi!
- (SK)** Nastavitelné nohy, ktoré sú na plánoch označené červeno, musia byť vždy umiestnené uprostred (vybrané) oblasti dverí!
- (SI)** Nastavljive noge, označene z rdečo na načrtih, morajo biti vedno nameščene na sredini (izbranega) območja vrat!
- (CZ)** Nastavitelné nohy, které jsou na plánech označeny červeně, musí být vždy umístěny uprostřed (vybrané) oblasti dveří!
- (HU)** A terveken pirossal színnel jelölt állítható lábakat mindig az ajtó területének közepére kell helyezni!
- (HR)** Podesive nožice označene crvenom bojom na planovima moraju uvijek biti postavljene u sredini (odabranog) područja vrata!

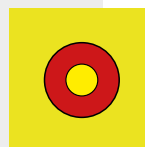

ACHTUNG: WENN EINE ZUSATZTÜR VERBAUT WIRD, WIRD AUCH MITTIG UNTER DER ZUSATZTÜR EIN WEITERER STELFFUSS BENÖTIGT!

- (GB)** ATTENTION: If an additional door is installed, an additional adjustable foot is also required in the middle under the additional door!
- (FR)** ATTENTION : Si une porte supplémentaire est installée, un pied réglable supplémentaire est également nécessaire au centre sous la porte supplémentaire !
- (NL)** LET OP: Als er een extra deur wordt geïnstalleerd, is er ook een extra verstelbare voet nodig in het midden onder de extra deur!
- (ES)** ATENCIÓN: Si se instala una puerta adicional, se requiere un pie ajustable adicional en el centro debajo de la puerta adicional!
- (IT)** ATTENZIONE: Se viene installata una porta aggiuntiva, è necessario anche un piedino regolabile aggiuntivo al centro sotto la porta aggiuntiva!
- (DK)** OBS: Hvis der er installeret en ekstra dør, kræves der også en ekstra justerbar fod i midten under den ekstra dør!
- (SE)** OBSERVERA: Om en extra dörr är installerad krävs också en extra justerbar fot mitt under den extra dörren!
- (NO)** OBS: Hvis det er installert en ekstra dør, kreves det også en ekstra justerbar fot i midten under den ekstra døren!
- (PL)** UWAGA: w przypadku zastosowania dodatkowych drzwi, również pod nimi konieczne jest zastosowanie dodatkowych stóp fundamentowych.
- (SK)** UPOZORNENIE: Ak sú nainštalované aj dodatočné dvere, aj pod tie je doprostred potrebné umiestniť ďalšiu nastaviteľnú nohu.
- (SI)** POZOR: Če so nameščena dodatna vrata, je na sredini pod dodatnimi vrati potrebna tudi dodatna nastavljiva noga!
- (CZ)** UPOZORNĚNÍ: Pokud jsou nainstalovány dodatečné dveře, i pod tyto dveře je doprostřed zapotřebí nainstalovat další nastavitelnou nohu!
- (HU)** FIGYELEM! Amennyiben egy pótajtó beépítésre kerül, a pótajtó alá egy további állítható lábakra kell kerülnie!
- (HR)** PAŽNJA: Ako su ugrađena dodatna vrata, potrebna je i dodatna podesiva noga u sredini ispod dodatnih vrata!



EUROPA

1



GERÄTESCHRANK

90, 150

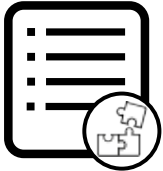

TEILEÜBERSICHT

Parts list · Liste des pièces · Stuklijst · Lista de piezas · Lista de parti · Deloversigt · Delöversikt · Del liste · Przegląd elementów · Zoznam dielov · Seznam delov · Seznam dílů · Tétélek áttekintése · Popis dijelova · Lista pieselor



PROFIL - STELLFUSSPAKET

Profile adjustable foot package · Colis des pieds réglables · Verstelbare voet – profiel · Perfil - Paquete de pies ajustables · Pacchetto base del profilo · Profil justerbare fødder pakke

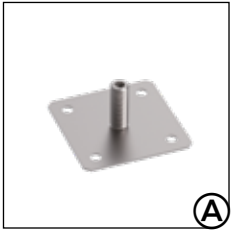

(A)

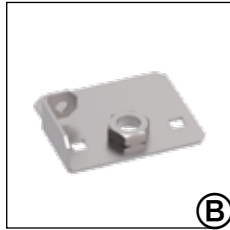

(B)

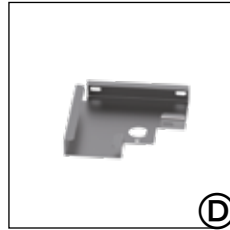

(D)

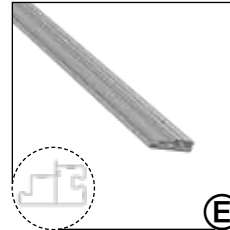

(E)

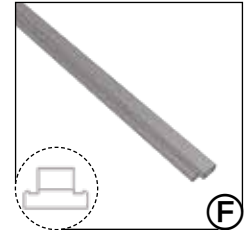

(F)

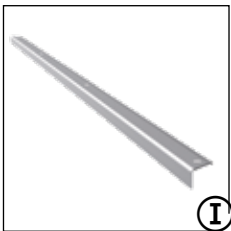

(I)



(U)



(D1)



DIELEN - PAKET

Floorboards package · Colis de lames · Plankenpakket · Pacco tavole per pavimento · Paquete de tablas de suelo · Gulvpakke

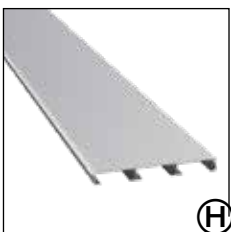

(H)



TEILEÜBERSICHT

Parts list · Liste des pièces · Stuklijst · Lista de piezas · Lista de parti · Deloversigt · Delöversikt · Del liste · Przegląd elementów · Zoznam dielov · Seznam delov · Seznam dílů · Tétélek áttekintése · Popis dijelova · Lista pieselor



1 STELLFUSS - PAKET

Adjustable foot package · Colis profilés des pieds réglables · Pakket verstelbare voet · Paquete de pies ajustables · Pacchetto piedini regolabili · Justerbare fødder pakke

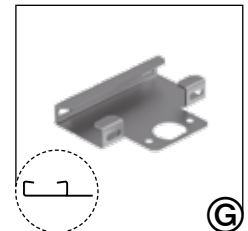
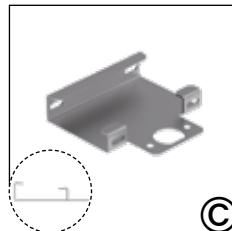
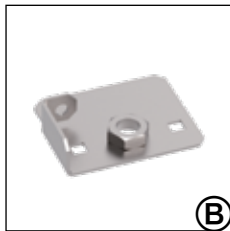
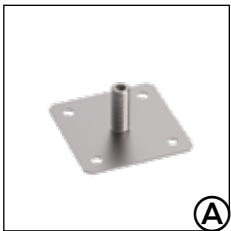

2 PROFIL - PAKET

Profile package · Carton de profils · Profielpakket · Pacco profili · Kit de perfiles · Profilpakke

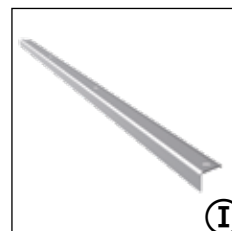
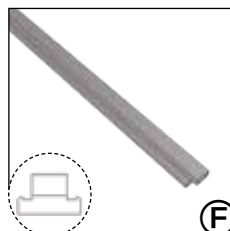
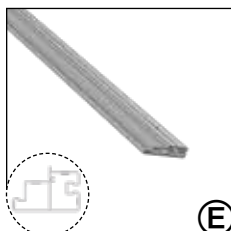

DIELEN - PAKET

Floorboards package · Colis de lames · Plankenpakket · Pacco tavole per pavimento · Paquete de tablas de suelo · Gulvpakke

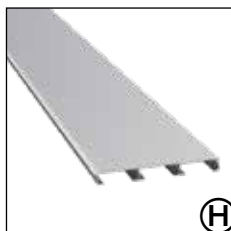

Fundamentplan

FOUNDATION PLAN | PLAN DE FONDATION | FUNDERINGSPLAN |
PLANO DE LOS CIMIENTOS | PIANO DI FONDAZIONE | FUNDAMENT PLAN



Geräteschrank

Equipment locker
Armoire à outils

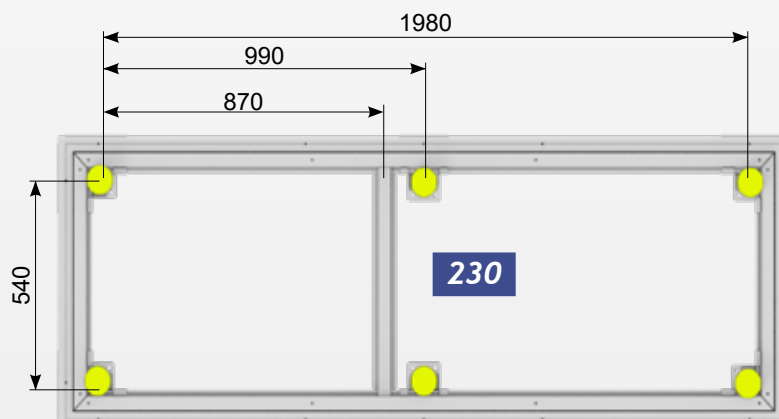
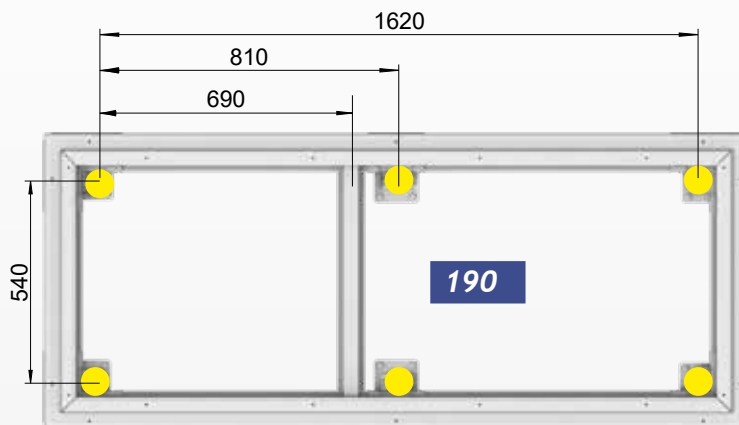
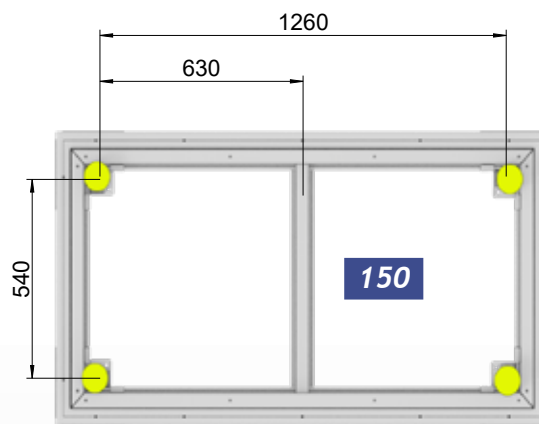
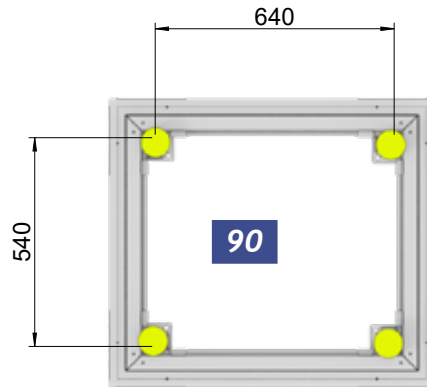

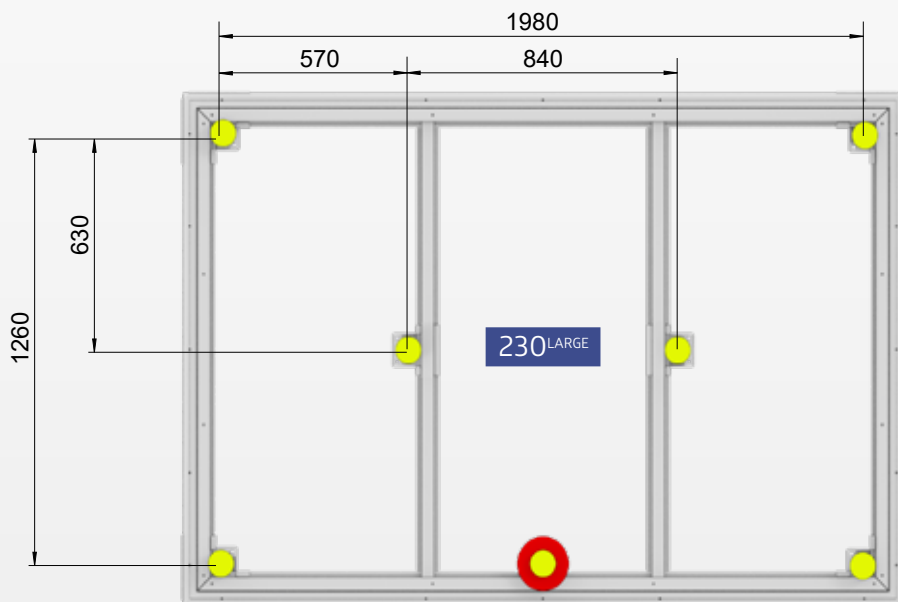
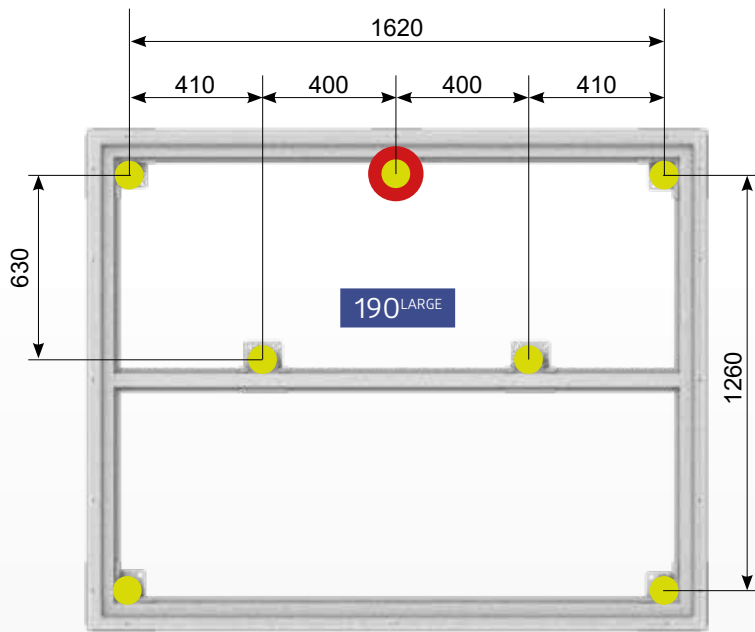
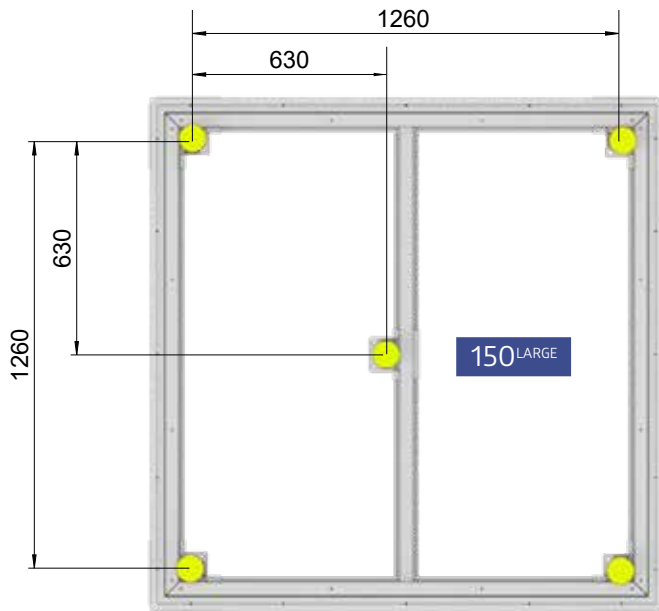



Europa

1

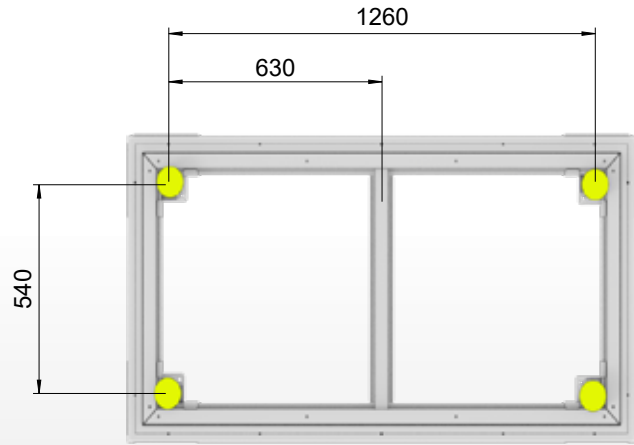

2

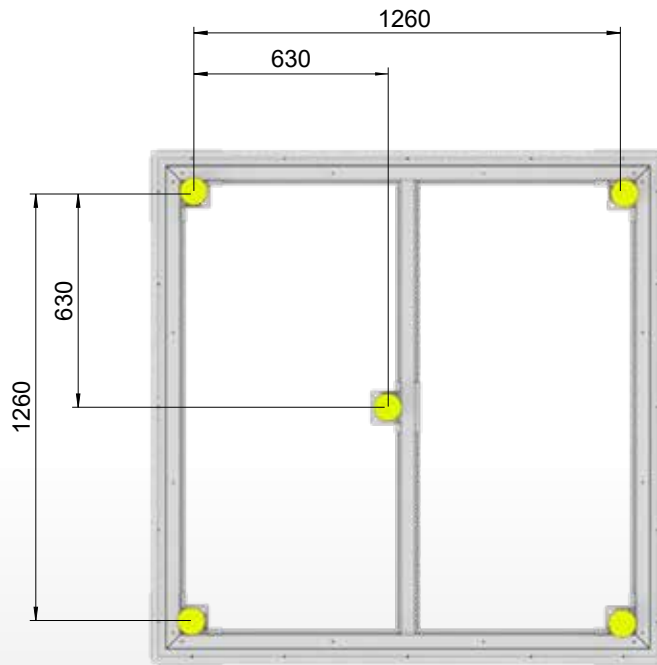

2A

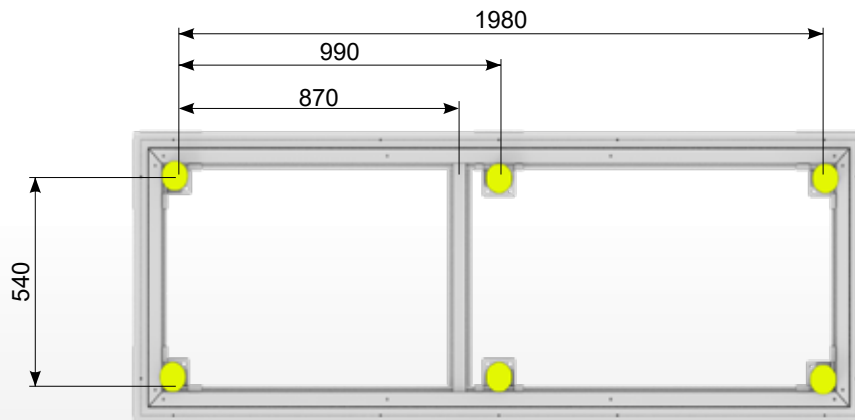

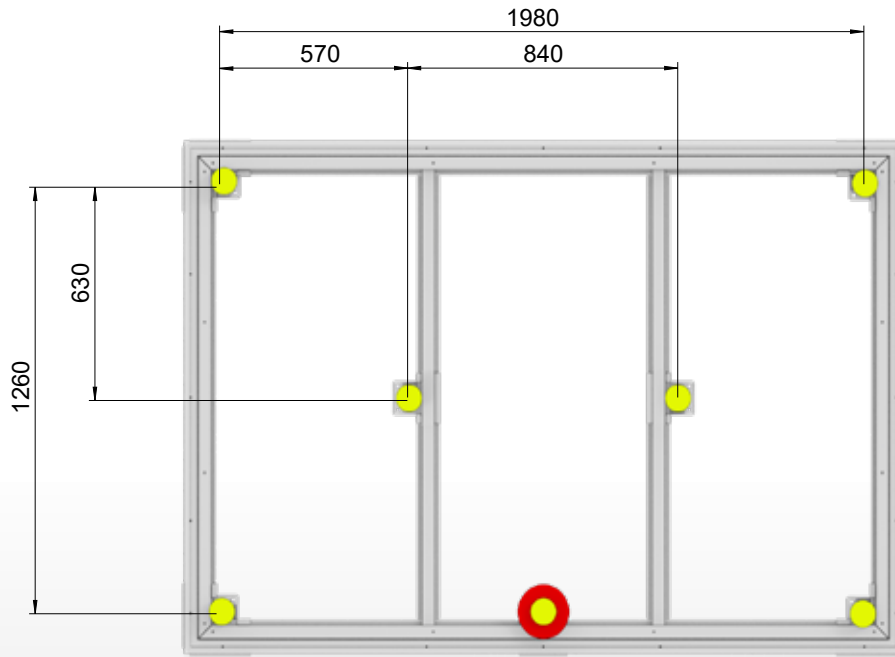

3

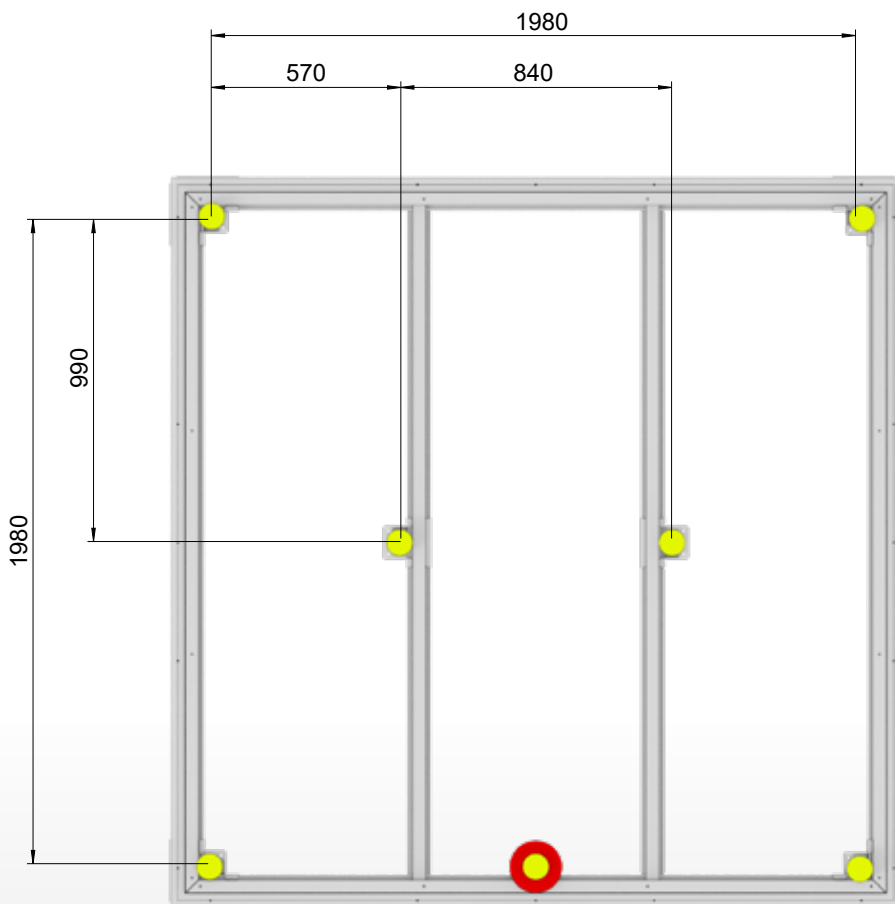

4

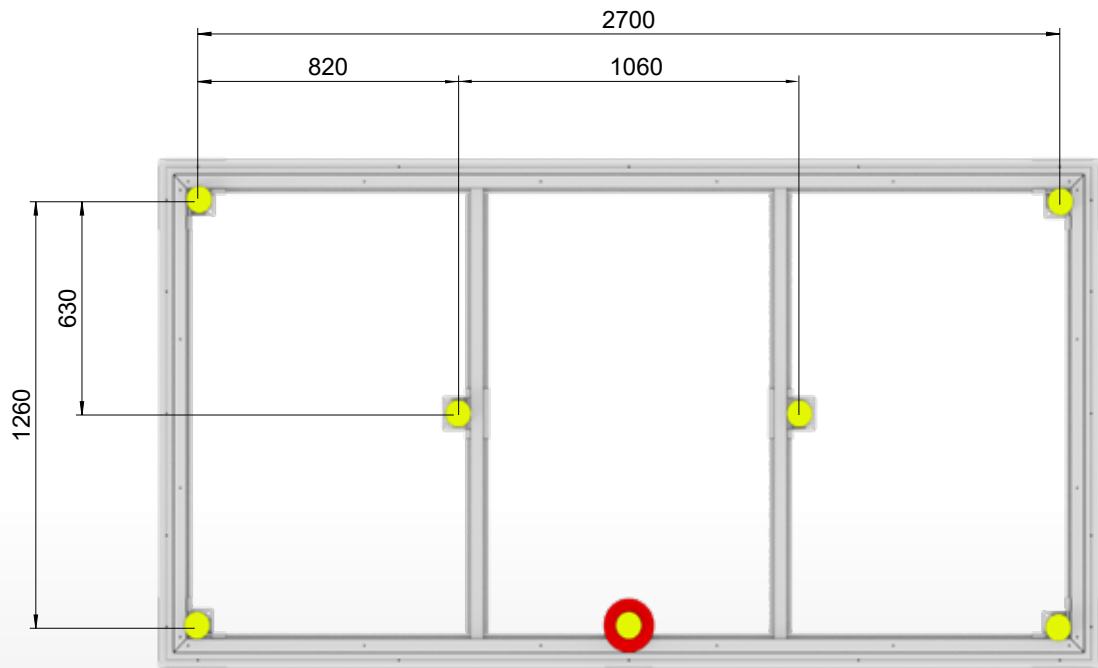

4A

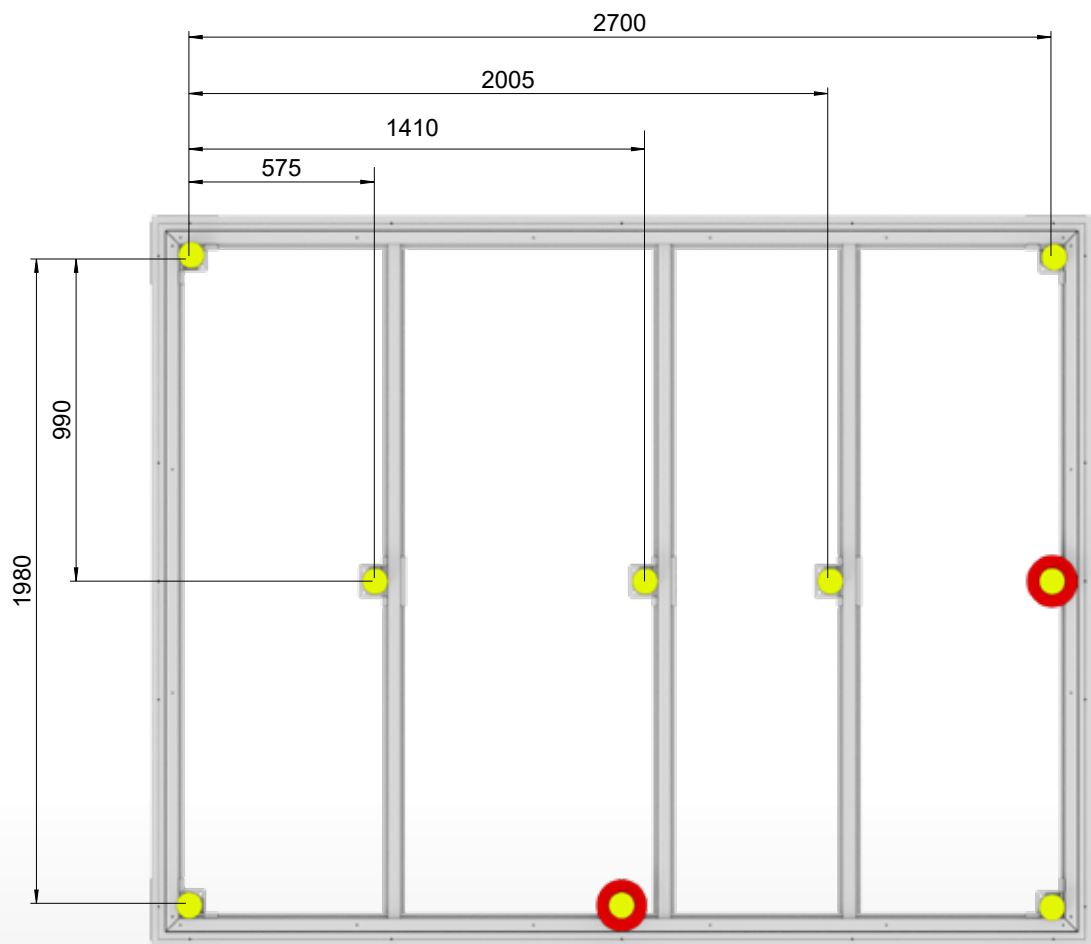

6

5, 6

5

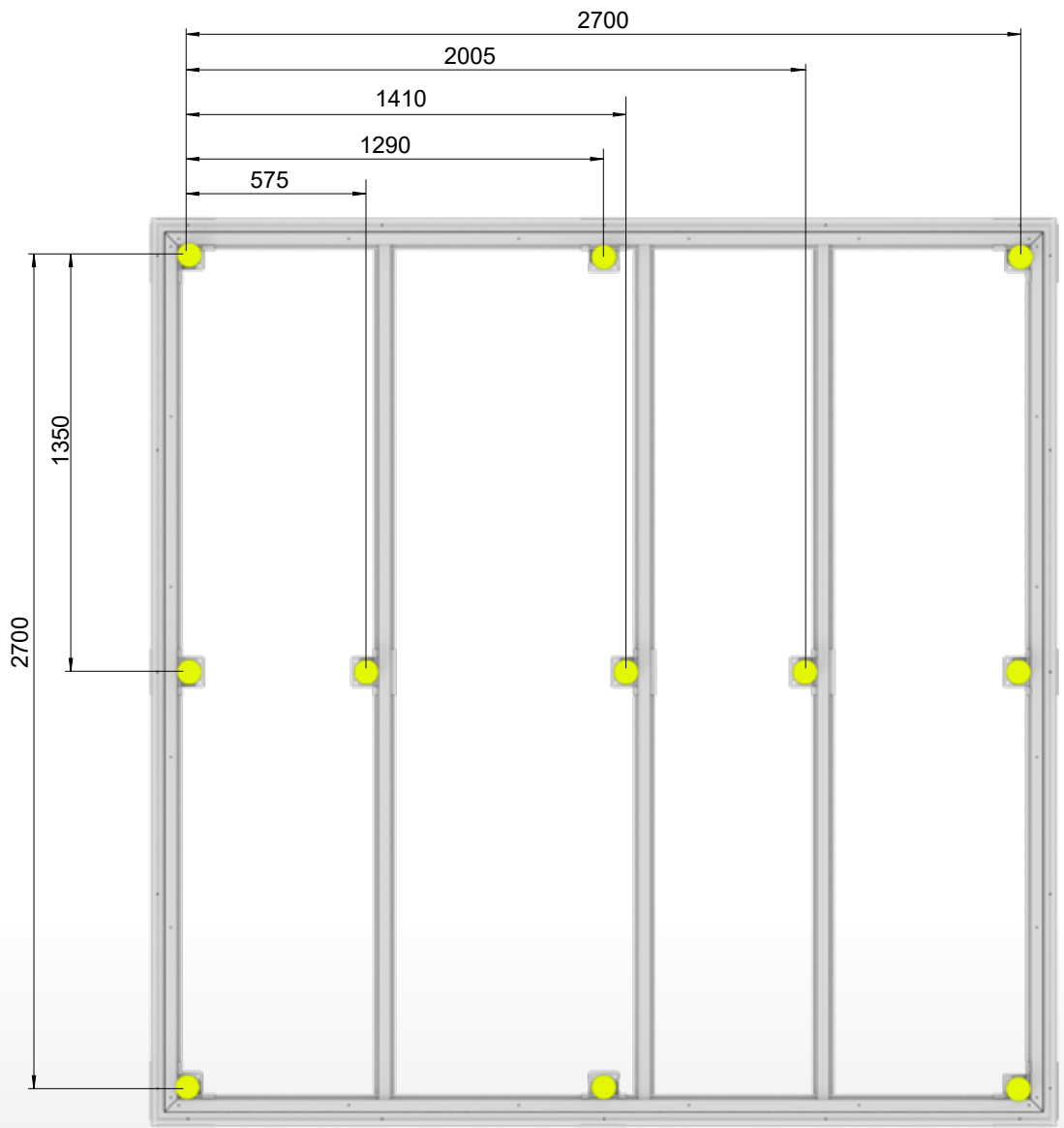

7



AvantGarde®

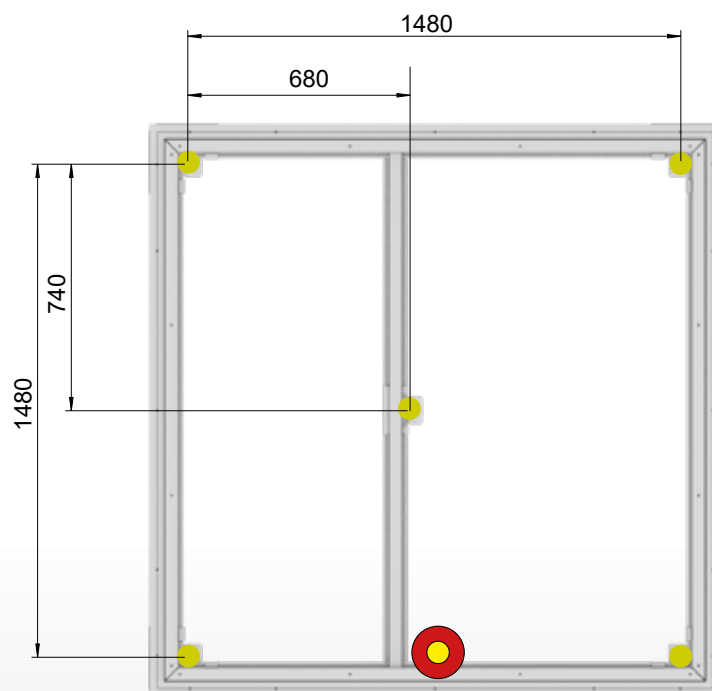

A1

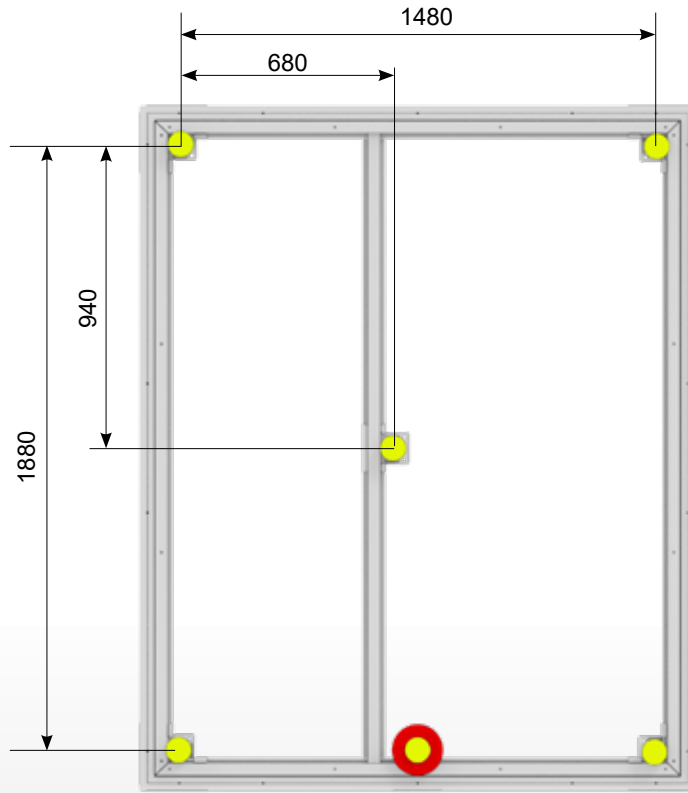

A2

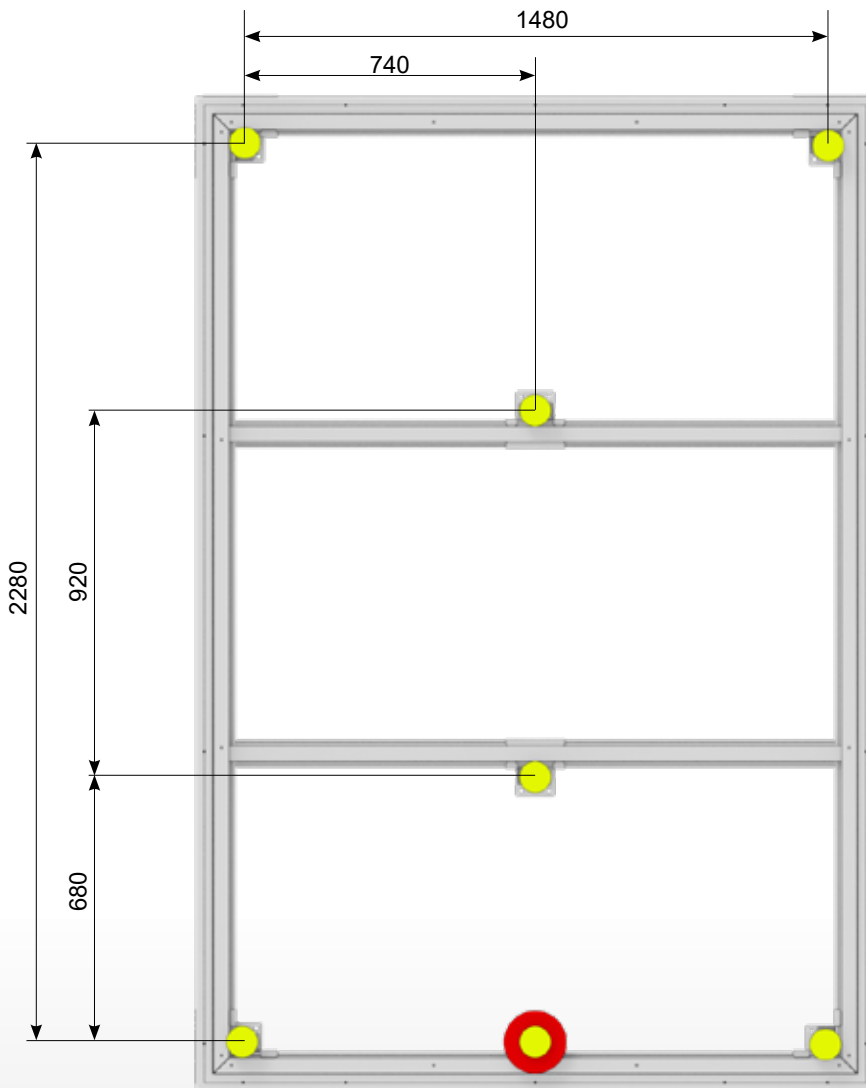

A3

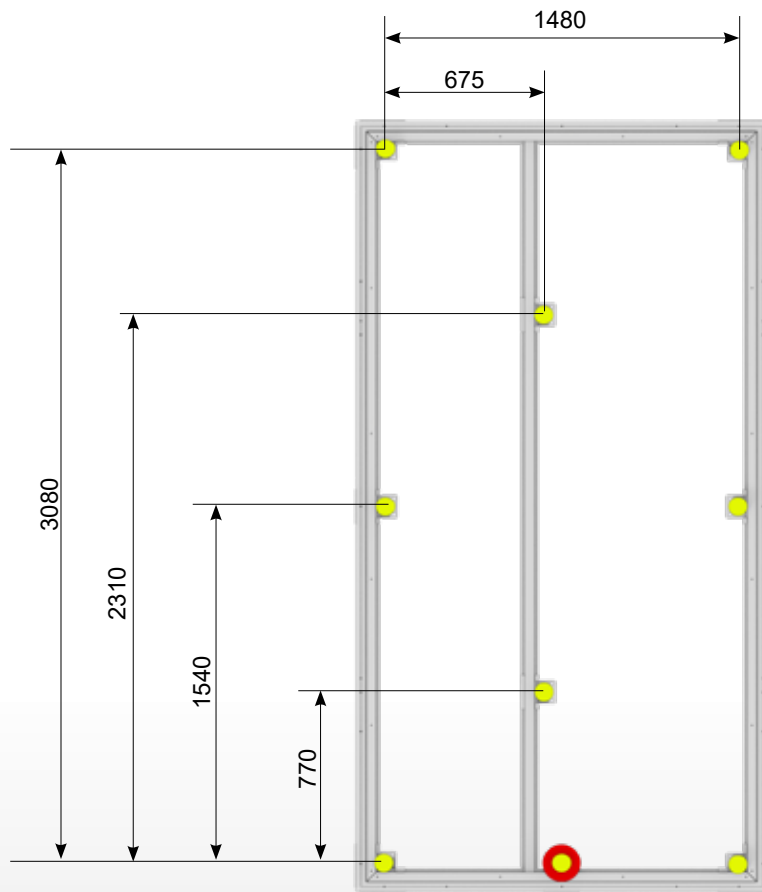

A4

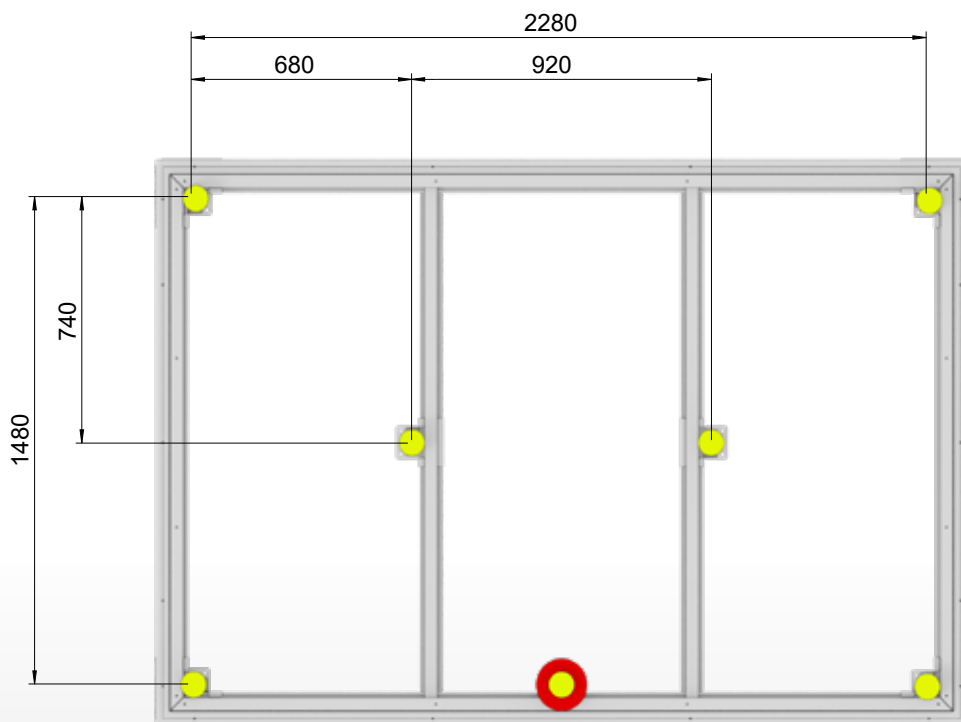

A5

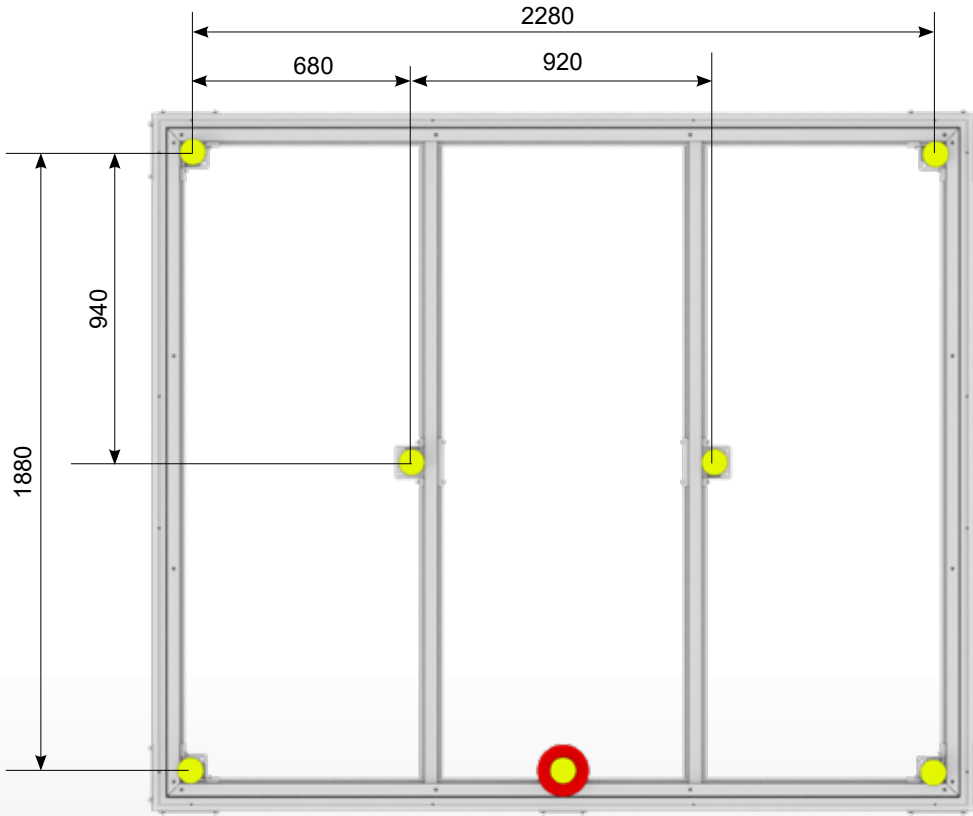

A6

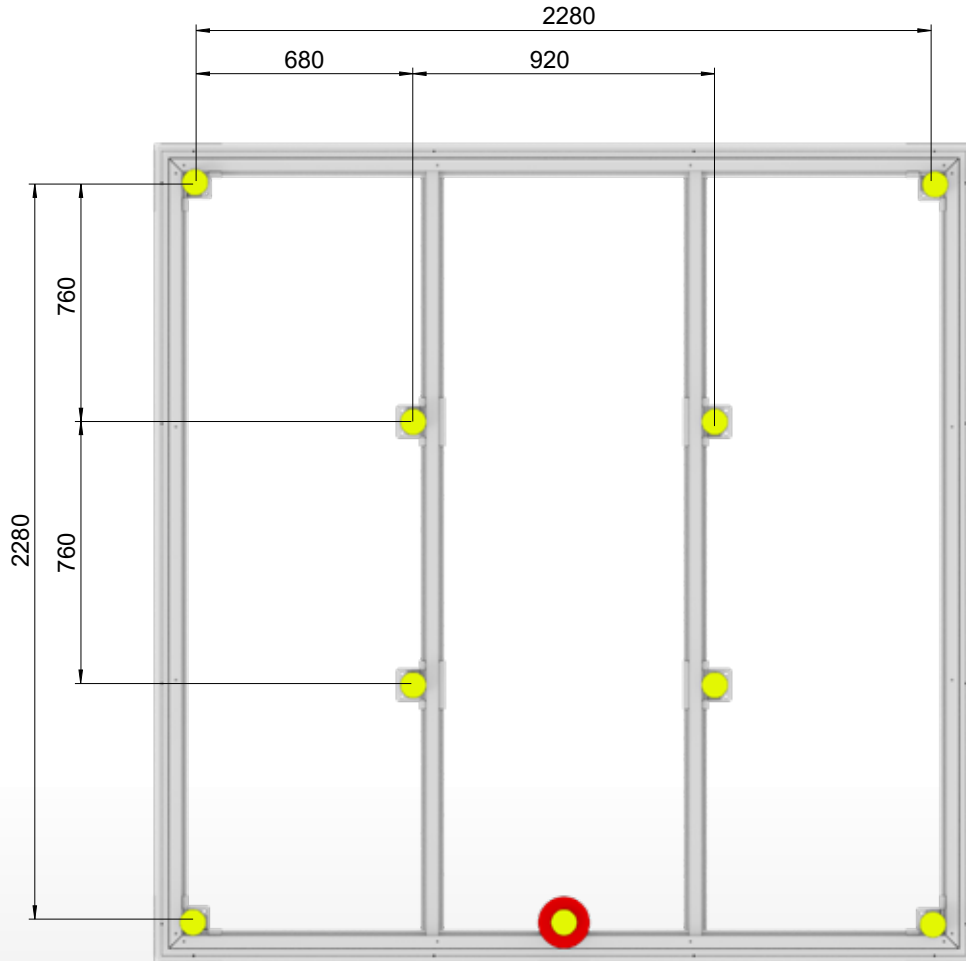

A7

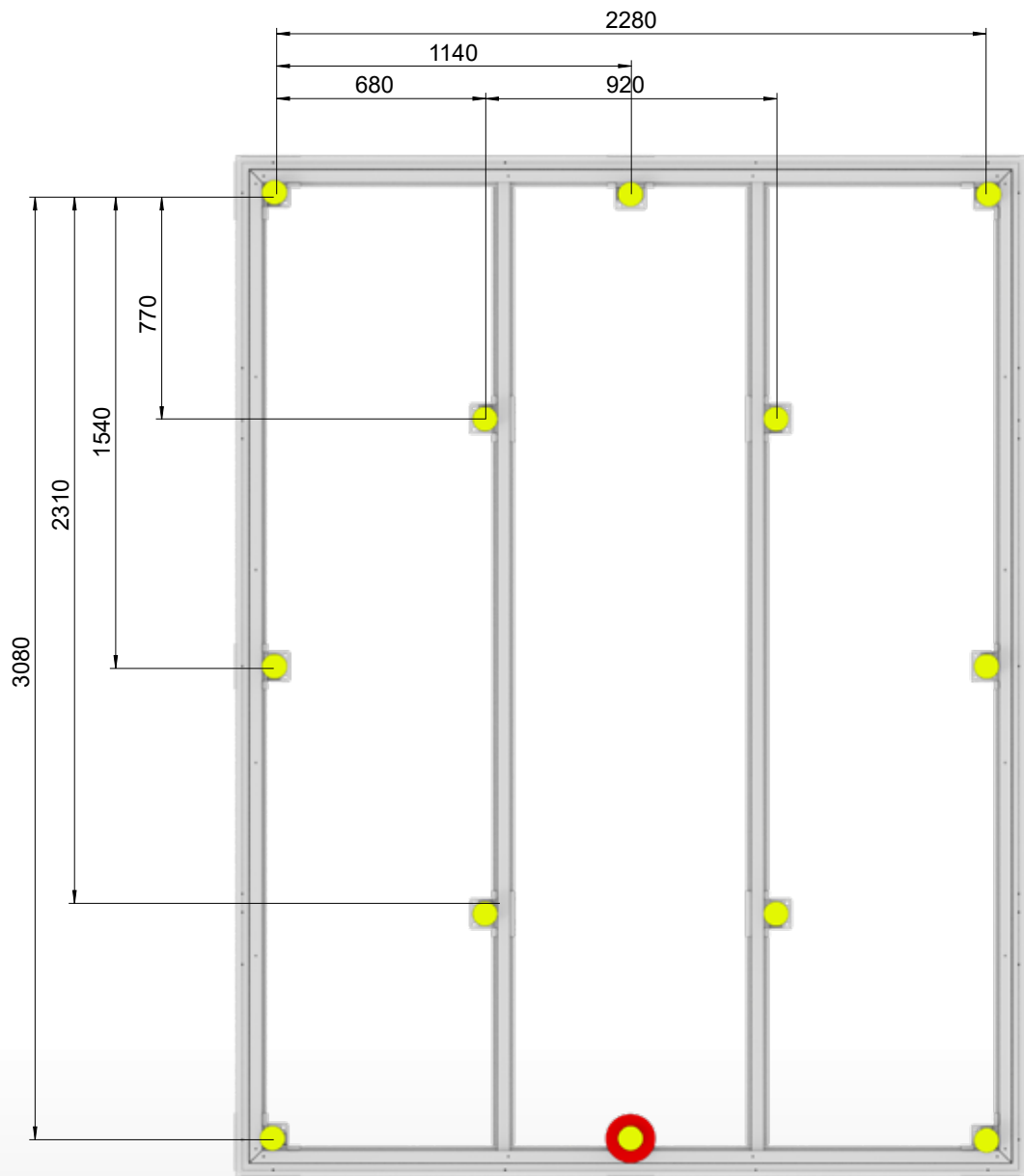

A8



HighLine®



Panorama®

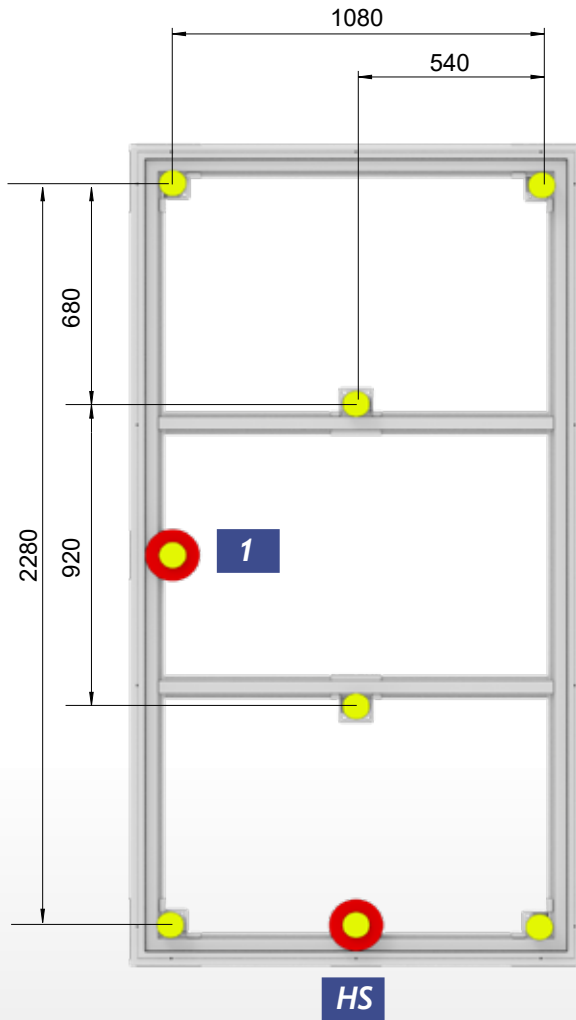

HS 1

HS

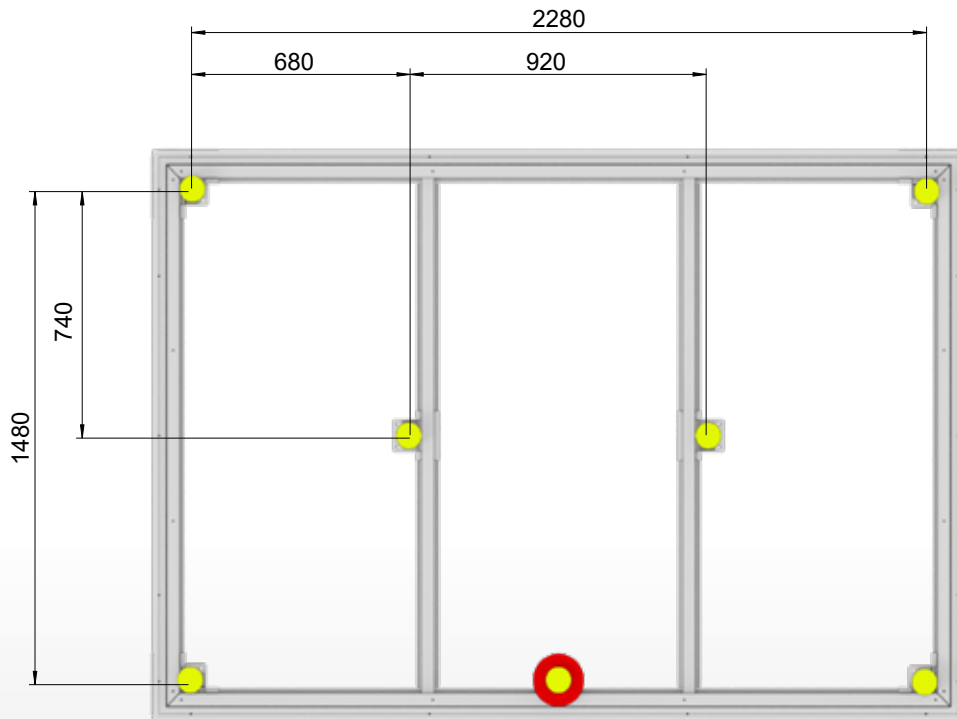

2

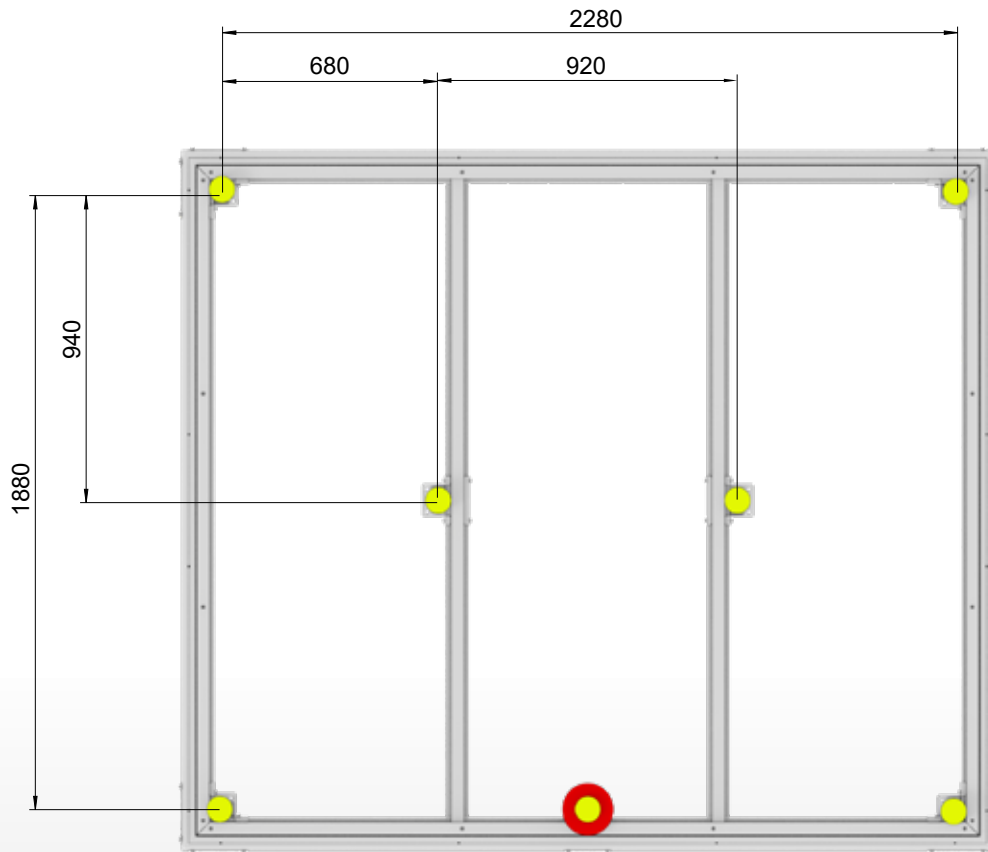

3

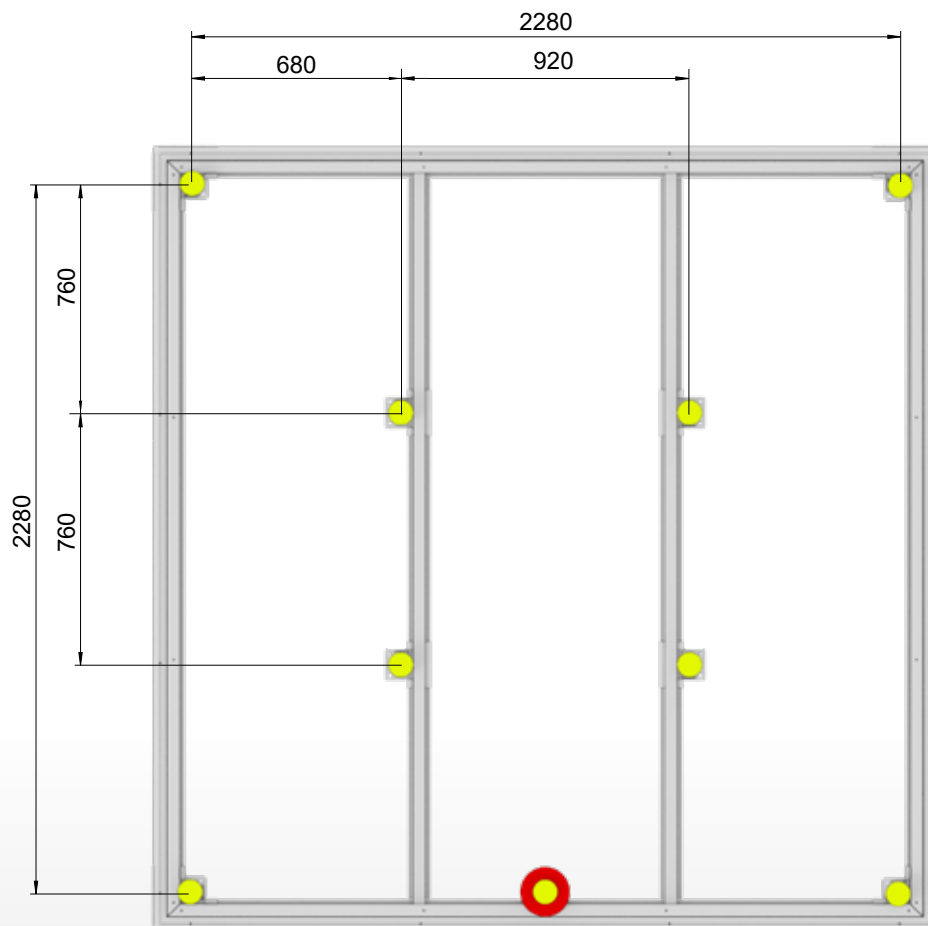

4

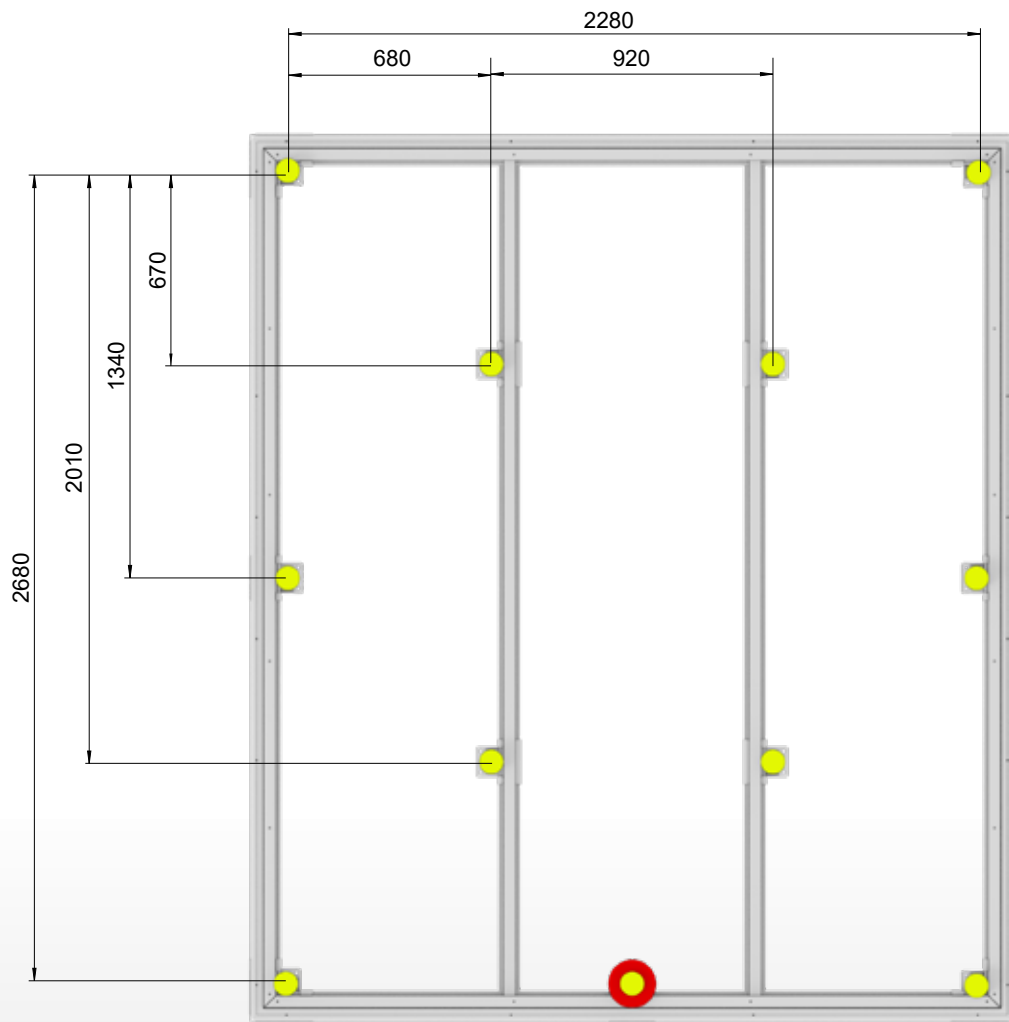

5

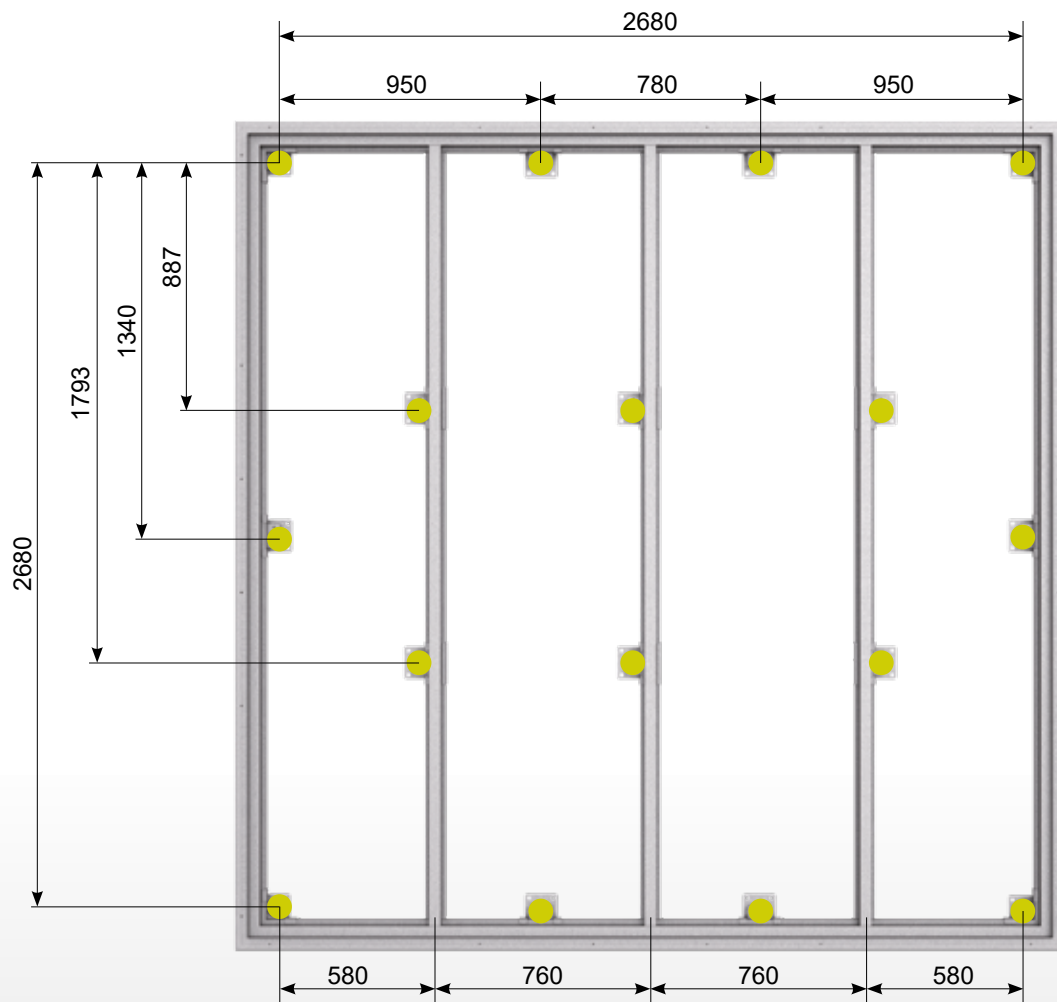

6



MiniGarage **L**

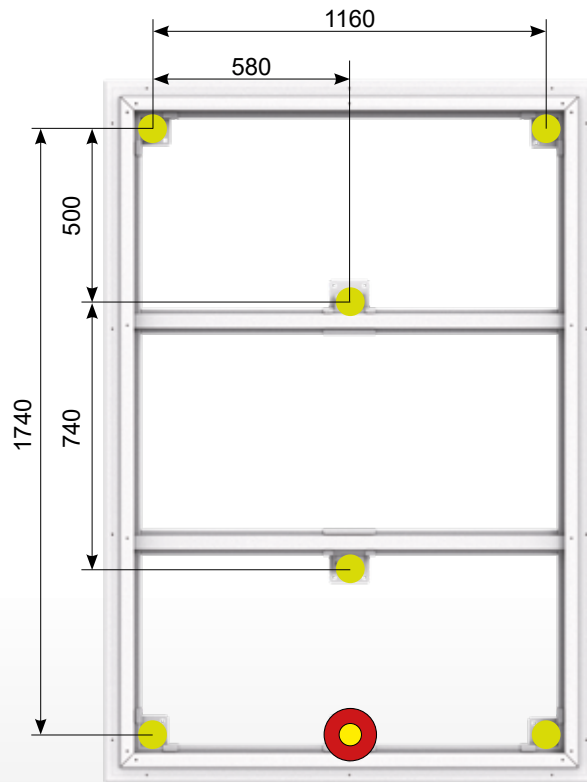



NEO

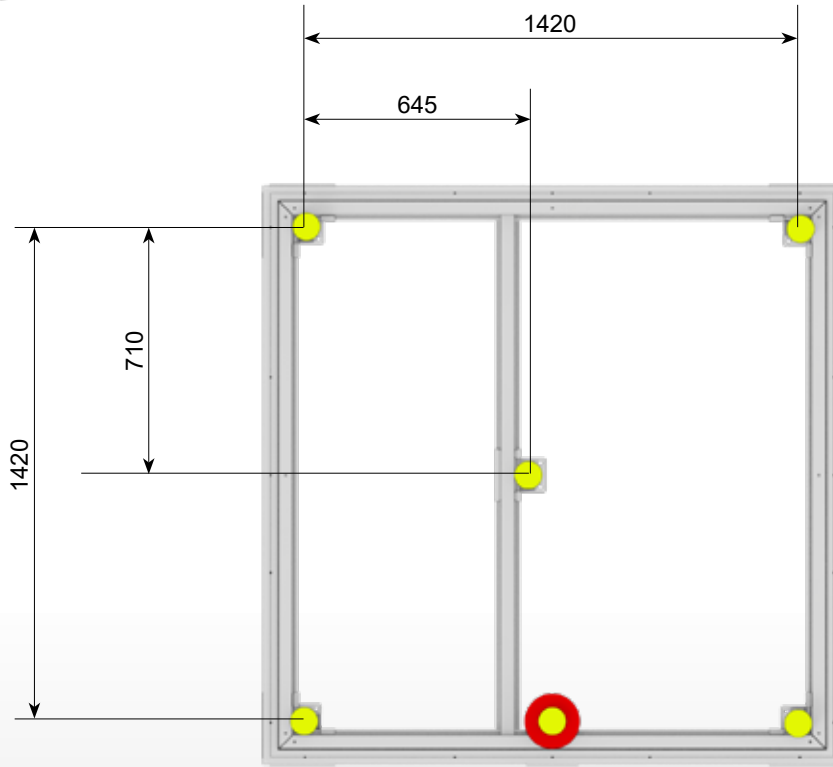

1A

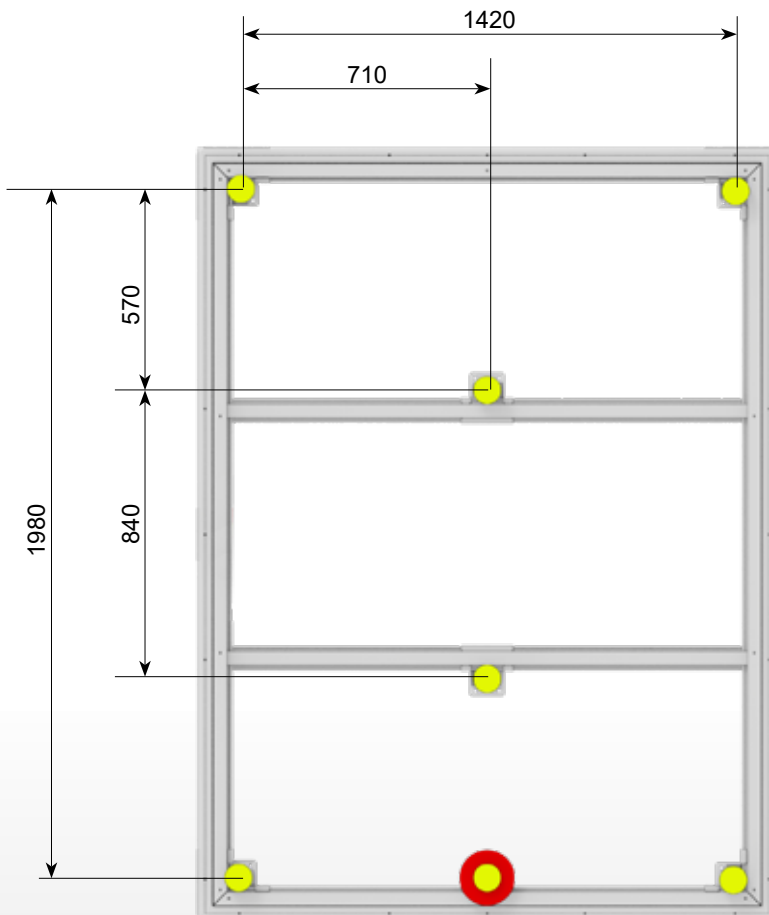

2A

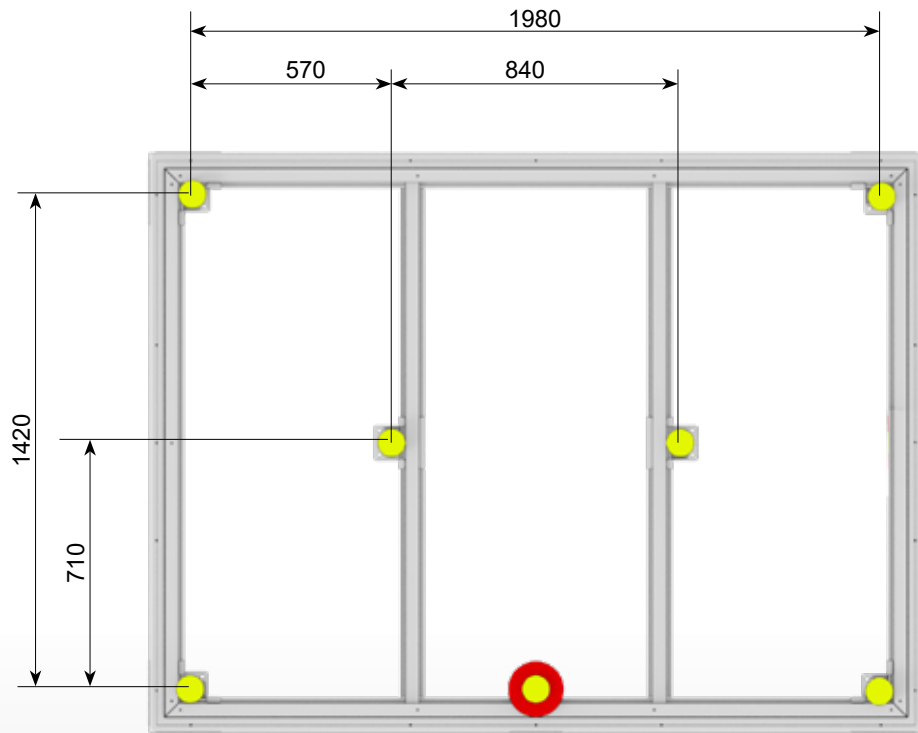



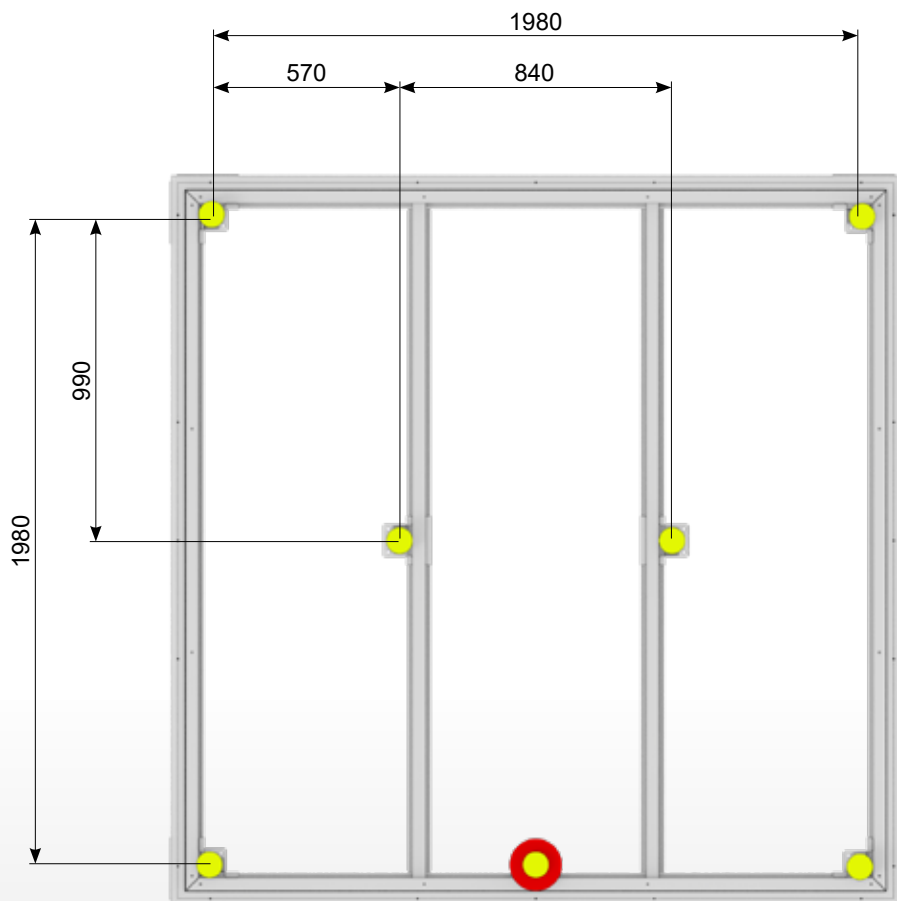

1B



2B

1.

 E	Europa 1: 2X (780mm) 2: 4X (1500mm) 2A: 2X (780mm) 3: 2X (1500mm)	Europa 4: 4X (2220mm) 4A: 2X (1500mm) 5: 2X (2220mm) 6: 2X (2220mm) 7: 4X (2940mm)	HighLine® Panorama® HS: 2X (1320mm) 1: 2X (1320mm) 2: 2X (1720mm) 3: 2X (2120mm) 4: 4X (2520mm) 5: 2X (2520mm) 6: 4X (2920mm)	AvantGarde® A1: 4X (1720mm) A2: 2X (1720mm) A3: 2X (1720mm) A4: 2X (1720mm) A5: 2X (2520mm) A6: 2X (2520mm) A7: 4X (2520mm) A8: 2X (2520mm)	Geräteschrank Equipment Locker Armoire à outils 90: 2X (780mm) 150: 2X (780mm) 190: 2X (780mm) 230: 2X (780mm) 150 ^{LARGE} : 4X(1500mm) 190 ^{LARGE} : 2X(1500mm) 230 ^{LARGE} : 2X(1500mm)	MiniGarage L: 2X (1980mm)
	NEO 1A: 4X (1660mm) 2A: 2X (2220mm) 1B: 2X (2220mm) 2B: 4X (2220mm)					
 E	Europa 1: 2X (1500mm) 2: 0X 2A: 2X (2220mm) 3: 2X (2220mm)	Europa 4: 0X 4A: 2X (2940mm) 5: 2X (2940mm) 6: 2X (2940mm) 7: 0X	HighLine® Panorama® HS: 2X (2520mm) 1: 2X (2520mm) 2: 2X (2520mm) 3: 2X (2520mm) 4: 0X 5: 2X (2920mm) 6: 0X	AvantGarde® A1: 0X A2: 2X (2120mm) A3: 2X (2520mm) A4: 2X (3220mm) A5: 2X (1720mm) A6: 2X (2120mm) A7: 0X A8: 2X (3220mm)	Geräteschrank Equipment Locker Armoire à outils 90: 2X (880mm) 150: 2X (1500mm) 190: 2X (1860mm) 230: 2X (2220mm) 150 ^{LARGE} : 0X 190 ^{LARGE} : 1X(1860mm) 230 ^{LARGE} : 2X(2200mm)	MiniGarage L: 2X (1400mm)
	NEO 1A: 0X 2A: 2X (1660mm) 1B: 2X (1660mm) 2B: 0X					
 C	Europa 1: 0X 2: 0X 2A: 2X 3: 1X	Europa 4: 1X 4A: 1X 5: 1X 6: 1X 7: 4X	HighLine® Panorama® HS: 1X 1: 1X 2: 1X 3: 1X 4: 1X 5: 3X 6: 6X	AvantGarde® A1: 1X A2: 1X A3: 1X A4: 3X A5: 1X A6: 1X A7: 1X A8: 4X	Geräteschrank Equipment Locker Armoire à outils 90: 0X 150: 0X 190: 2X 230: 2X 150 ^{LARGE} : 0X 190 ^{LARGE} : 2X 230 ^{LARGE} : 1X	MiniGarage L: 1x
	NEO 1A: 1X 2A: 1X 1B: 1X 2B: 1X					
4,8 x 60  D1	4x	 D	4x			

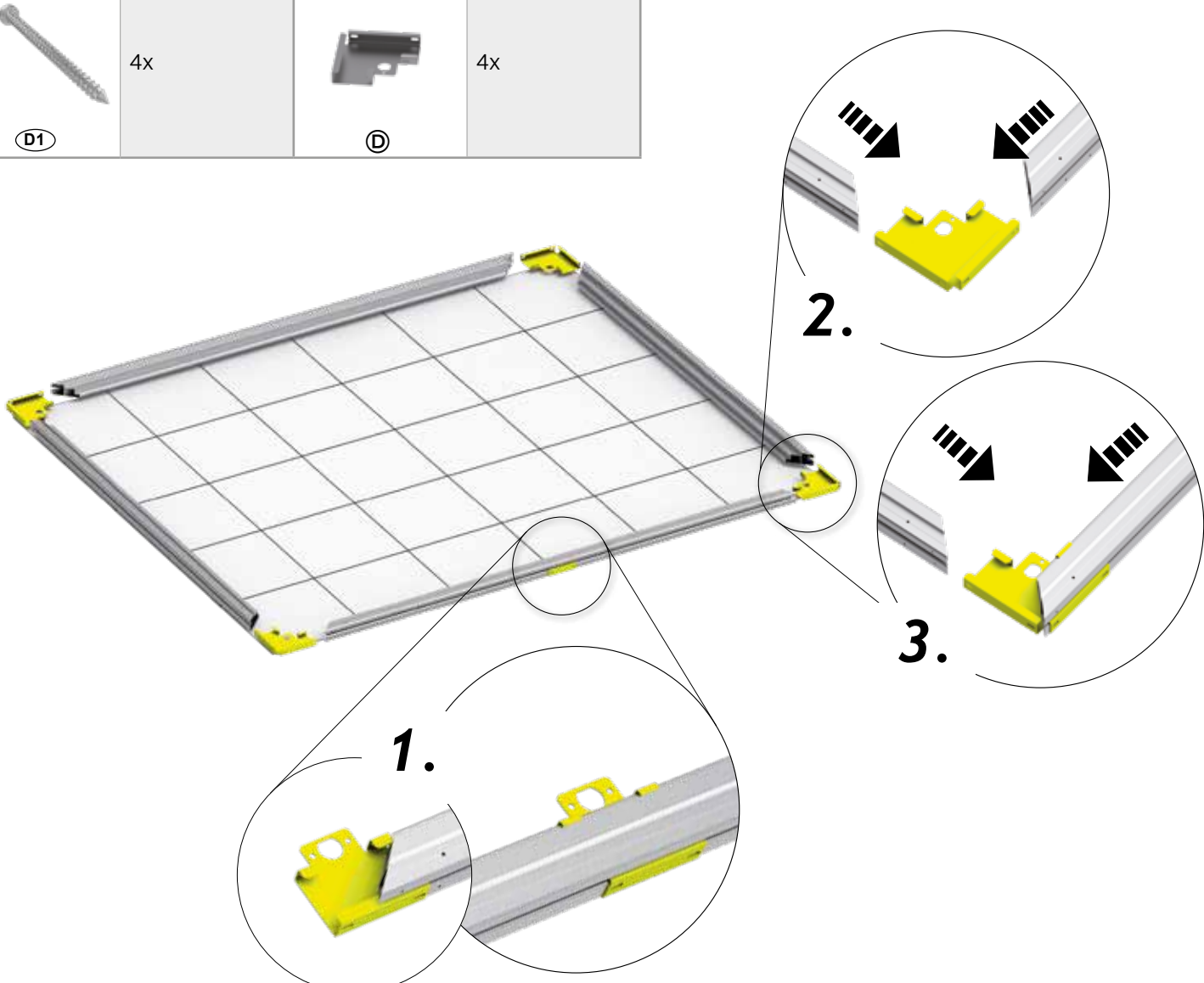

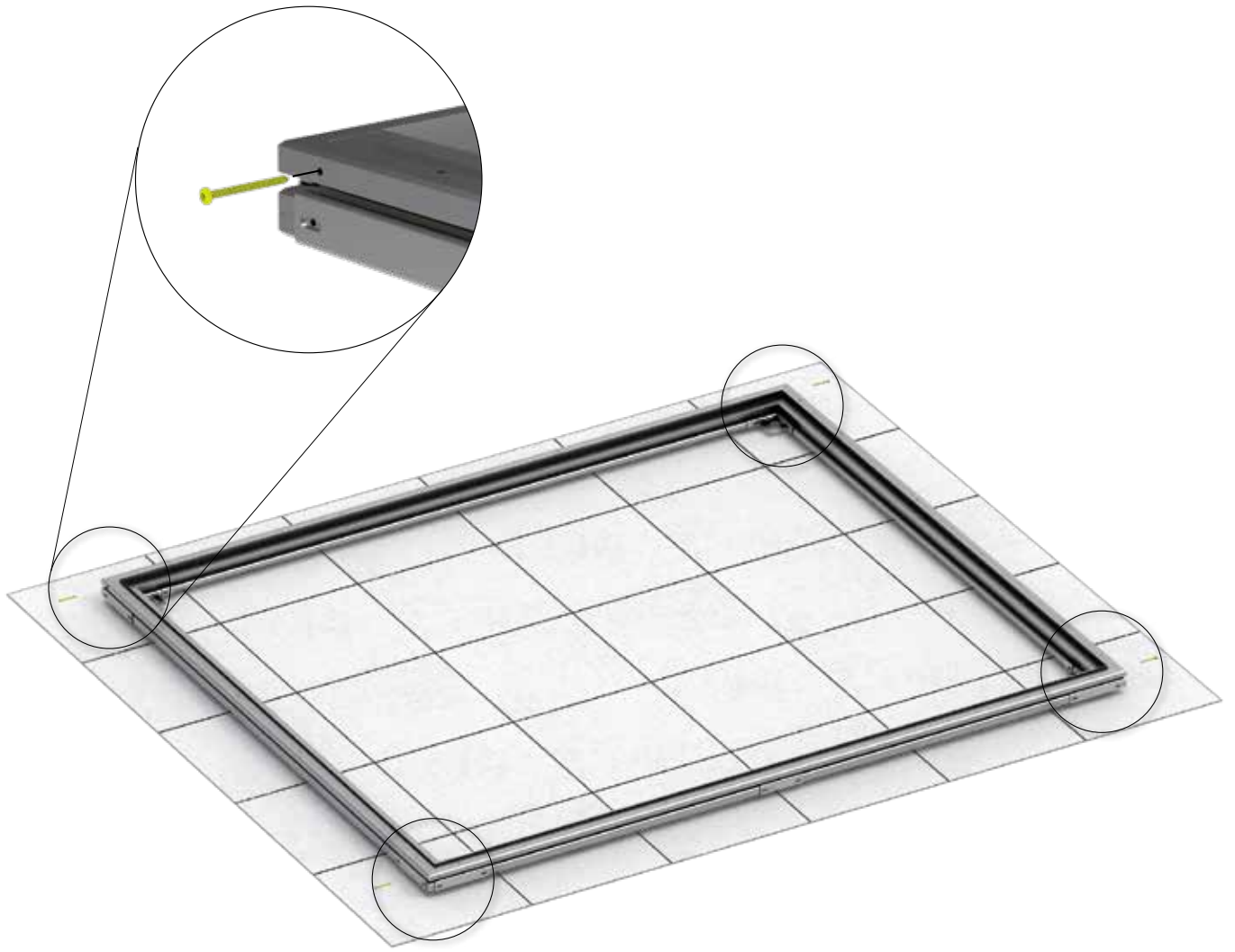

2.



Europa

- 1: 1X (614mm)
- 2: 1X (1334mm)
- 2A: 1X (614mm)
- 3: 2X (1334mm)

Europa

- 4: 2X (2054mm)
- 4A: 2X (1334mm)
- 5: 3X (2054mm)
- 6: 3X (2054mm)
- 7: 3X (2774mm)

**HighLine®
Panorama®**

- HS: 2X (1154mm)
- 1: 2X (1154mm)
- 2: 2X (1554mm)
- 3: 2X (1954mm)
- 4: 2X (2354mm)
- 5: 2X (2754mm)
- 6: 3X (2754mm)

AvantGarde®

- A1: 1X (1554mm)
- A2: 1X (1954mm)
- A3: 2X (1554mm)
- A4: 1X (3154mm)
- A5: 2X (1554mm)
- A6: 2X (1954mm)
- A7: 2X (2354mm)
- A8: 2X (3154mm)

Geräteschrank

- Equipment Locker
Armoire à outils
- 90: 0X
 - 150: 1X (614mm)
 - 190: 1X (614mm)
 - 230: 1X (614mm)
 - 150^{LARGE}: 1X(1434mm)
 - 190^{LARGE}: 2X(1696mm)
 - 230^{LARGE}: 2X(1434mm)

MiniGarage

- L: 2X (1234mm)
- NEO**
- 1A: 1X (1494mm)
 - 2A: 2X (1494mm)
 - 1B: 2X (1494mm)
 - 2B: 2X (2054mm)

Ⓕ



Europa

- 1: 0X
- 2: 1X
- 2A: 0X
- 3: 2X

Europa

- 4: 2X
- 4A: 2X
- 5: 3X
- 6: 3X
- 7: 3X

**HighLine®
Panorama®**

- HS: 2X
- 1: 2X
- 2: 2X
- 3: 2X
- 4: 4X
- 5: 4X
- 6: 6X

AvantGarde®

- A1: 1X
- A2: 1X
- A3: 2X
- A4: 2X
- A5: 2X
- A6: 2X
- A7: 4X
- A8: 4X

Geräteschrank

- Equipment Locker
Armoire à outils
- 90: 0X
 - 150: 0X
 - 190: 0X
 - 230: 0X
 - 150^{LARGE}: 1X
 - 190^{LARGE}: 2X
 - 230^{LARGE}: 2X

MiniGarage

- L: 2X
- NEO**
- 1A: 1X
 - 2A: 2X
 - 1B: 2X
 - 2B: 2X

Ⓖ

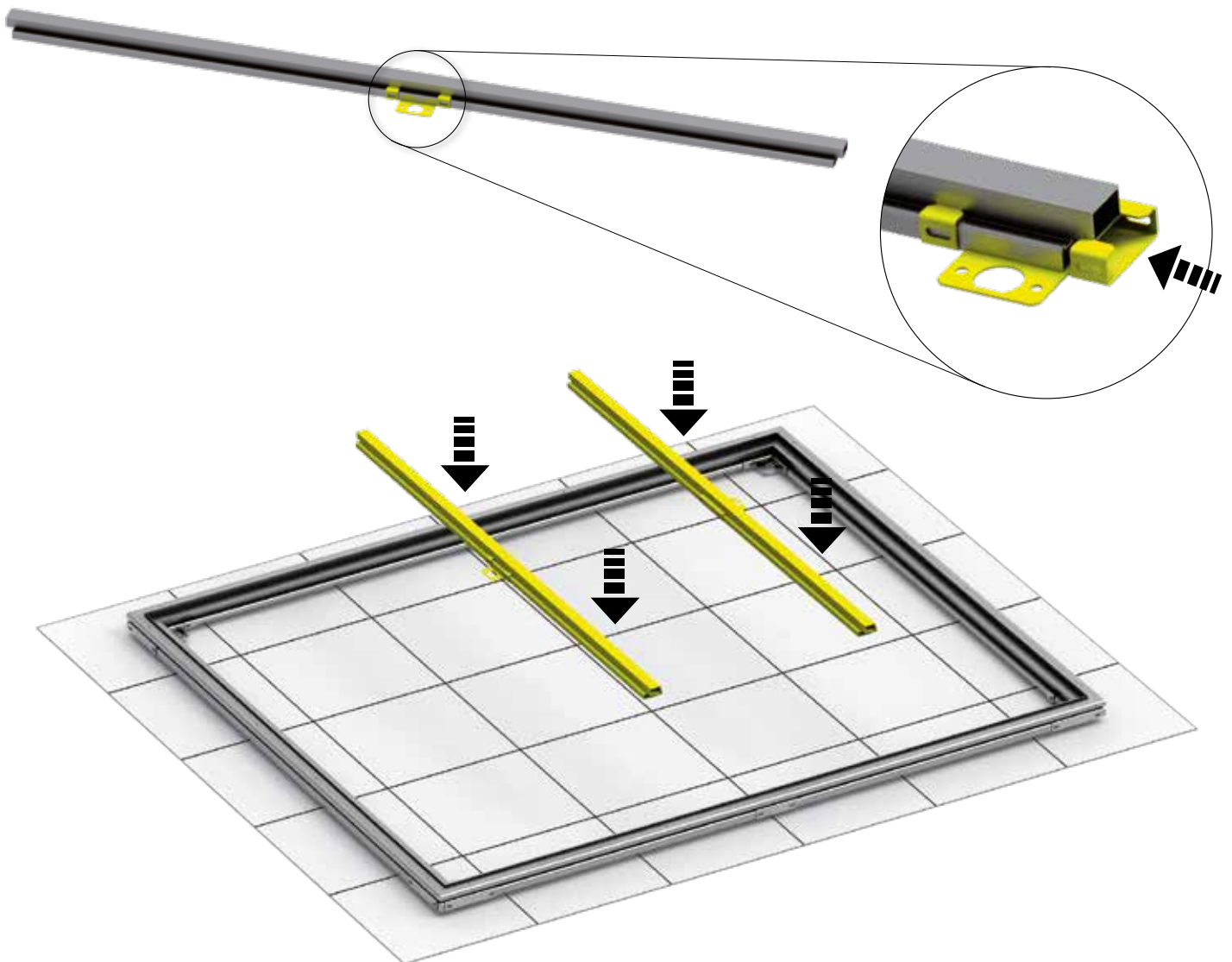

6,3 x 22 *



D1

Europa

- 1: 24x
- 2: 28x
- 2A: 32x
- 3: 36x

Europa

- 4: 36x
- 4A: 36x
- 5: 40x
- 6: 40x
- 7: 52x

**HighLine®
Panorama®**

- HS: 36x
- 1: 36x
- 2: 36x
- 3: 36x
- 4: 44x
- 5: 52x
- 6: 80x

AvantGarde®

- A1: 32x
- A2: 32x
- A3: 36x
- A4: 44x
- A5: 36x
- A6: 36x
- A7: 44x
- A8: 56x

Geräteschrank

Equipment Locker

Armoire à outils

- 90: 24x
- 150: 24x
- 190: 32x
- 230: 32x
- 150^{LARGE}: 28x
- 190^{LARGE}: 36x
- 230^{LARGE}: 36x

MiniGarage

L: 36x



NEO

- 1A: 32x
- 2A: 36x
- 1B: 36x
- 2B: 36x

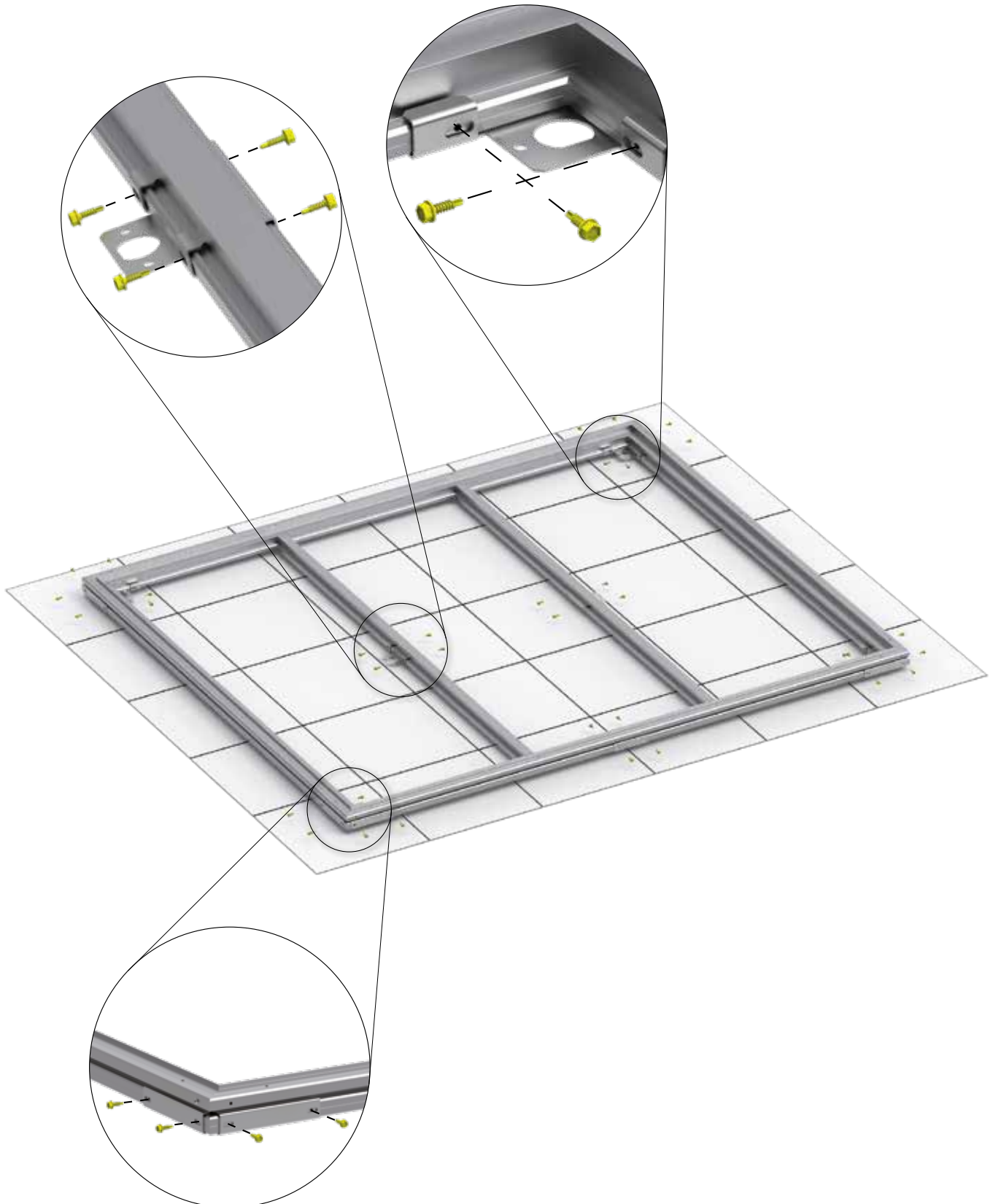
*Selbstschneidende Schraube
Self-tapping screw - Vis autotaraudeuse





4.

 <p>B</p>	<p>Europa</p> <p>1: 4x 2: 5x 2A: 6x 3: 7x</p>	<p>Europa</p> <p>4: 7x 4A: 7x 5: 8x 6: 8x 7: 11x</p>	<p>HighLine® Panorama®</p> <p>HS: 7x 1: 7x 2: 7x 3: 7x 4: 9x 5: 11x 6: 16x</p>	<p>AvantGarde®</p> <p>A1: 6x A2: 6x A3: 7x A4: 9x A5: 7x A6: 7x A7: 9x A8: 12x</p>	<p>Geräteschrank Equipment Locker Armoire à outils</p> <p>90: 4x 150: 4x 190: 6x 230: 6x 150^{LARGE}: 5x 190^{LARGE}: 7x 230^{LARGE}: 7x</p>	<p>MiniGarage L: 7x</p> <hr/> <p>NEO</p> <p>1A: 6x 2A: 7x 1B: 7x 2B: 7x</p>
<p>6,3 x 22 *</p>  <p>D1</p>	<p>Europa</p> <p>1: 4x 2: 5x 2A: 6x 3: 7x</p>	<p>Europa</p> <p>4: 7x 4A: 7x 5: 8x 6: 8x 7: 11x</p>	<p>HighLine® Panorama®</p> <p>HS: 7x 1: 7x 2: 7x 3: 7x 4: 9x 5: 11x 6: 16x</p>	<p>AvantGarde®</p> <p>A1: 6x A2: 6x A3: 7x A4: 9x A5: 7x A6: 7x A7: 9x A8: 12x</p>	<p>Geräteschrank Equipment Locker Armoire à outils</p> <p>90: 4x 150: 4x 190: 6x 230: 6x 150^{LARGE}: 5x 190^{LARGE}: 7x 230^{LARGE}: 7x</p>	<p>MiniGarage L: 7x</p> <hr/> <p>NEO</p> <p>1A: 6x 2A: 7x 1B: 7x 2B: 7x</p>
<p>M8 x 20</p>  <p>D1</p>	<p>Europa</p> <p>1: 4x 2: 6x 2A: 8x 3: 10x</p>	<p>Europa</p> <p>4: 10x 4A: 10x 5: 12x 6: 12x 7: 18x</p>	<p>HighLine® Panorama®</p> <p>HS: 10x 1: 10x 2: 10x 3: 10x 4: 14x 5: 18x 6: 36x</p>	<p>AvantGarde®</p> <p>A1: 8x A2: 8x A3: 10x A4: 14x A5: 10x A6: 10x A7: 14x A8: 20x</p>	<p>Geräteschrank Equipment Locker Armoire à outils</p> <p>90: 4x 150: 4x 190: 8x 230: 8x 150^{LARGE}: 6x 190^{LARGE}: 10x 230^{LARGE}: 10x</p>	<p>MiniGarage L: 10x</p> <hr/> <p>NEO</p> <p>1A: 8x 2A: 10x 1B: 10x 2B: 10x</p>

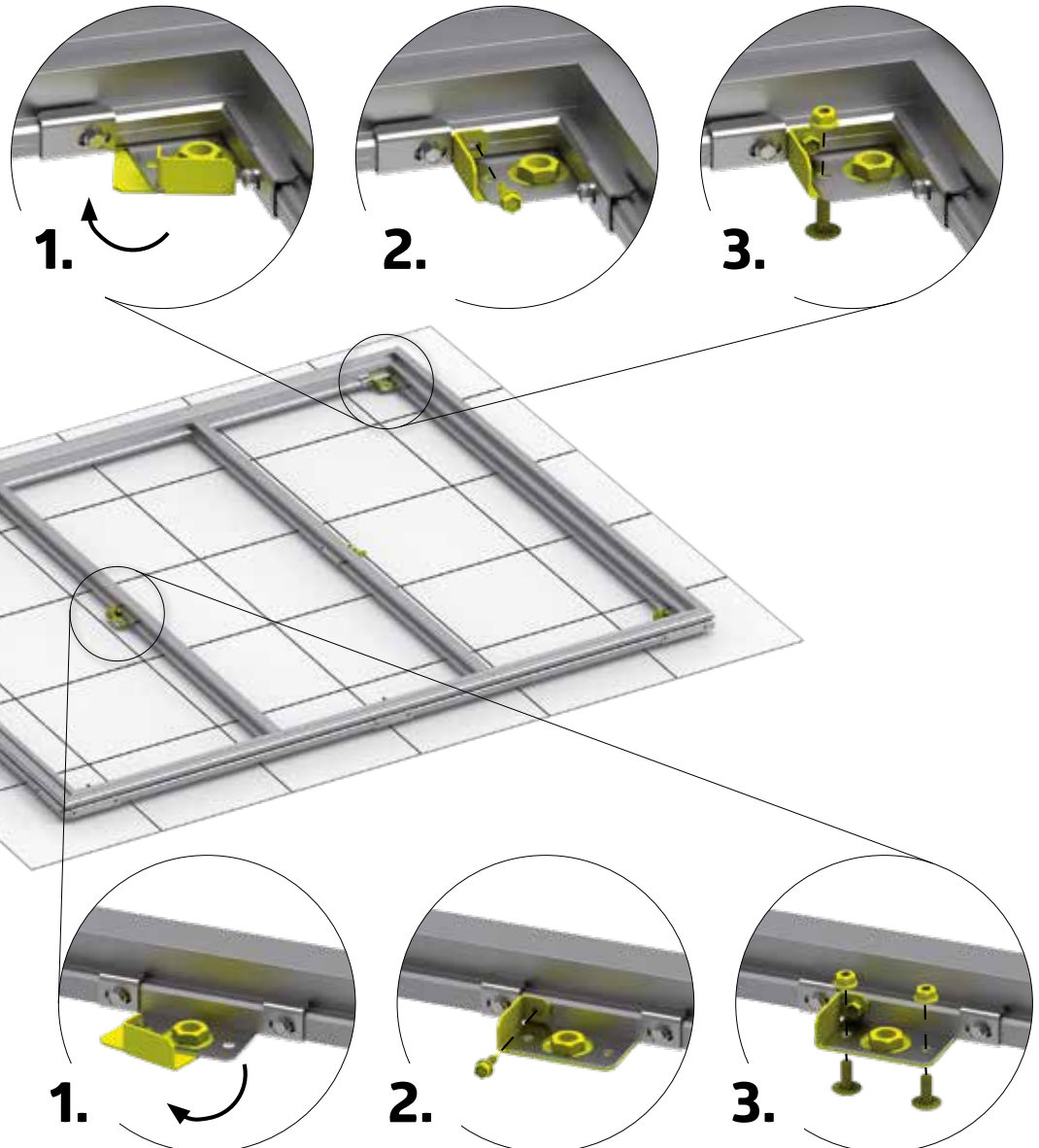
*Selbstschneidende Schraube
Self-tapping screw - Vis autotaraudeuse



5.

 	Europa 1: 4x 2: 5x 2A: 6x 3: 7x	Europa 4: 7x 4A: 7x 5: 8x 6: 8x 7: 11x	HighLine® Panorama® HS: 7x 1: 7x 2: 7x 3: 7x 4: 9x 5: 11x 6: 16x	AvantGarde® A1: 6x A2: 6x A3: 7x A4: 9x A5: 7x A6: 7x A7: 9x A8: 12x	Geräteschrank Equipment Locker Armoire à outils 90: 4x 150: 4x 190: 6x 230: 6x 150 ^{LARGE} : 5x 190 ^{LARGE} : 7x 230 ^{LARGE} : 7x	MiniGarage L: 7x <hr/> NEO 1A: 6x 2A: 7x 1B: 7x 2B: 7x
--	--	--	--	---	--	--

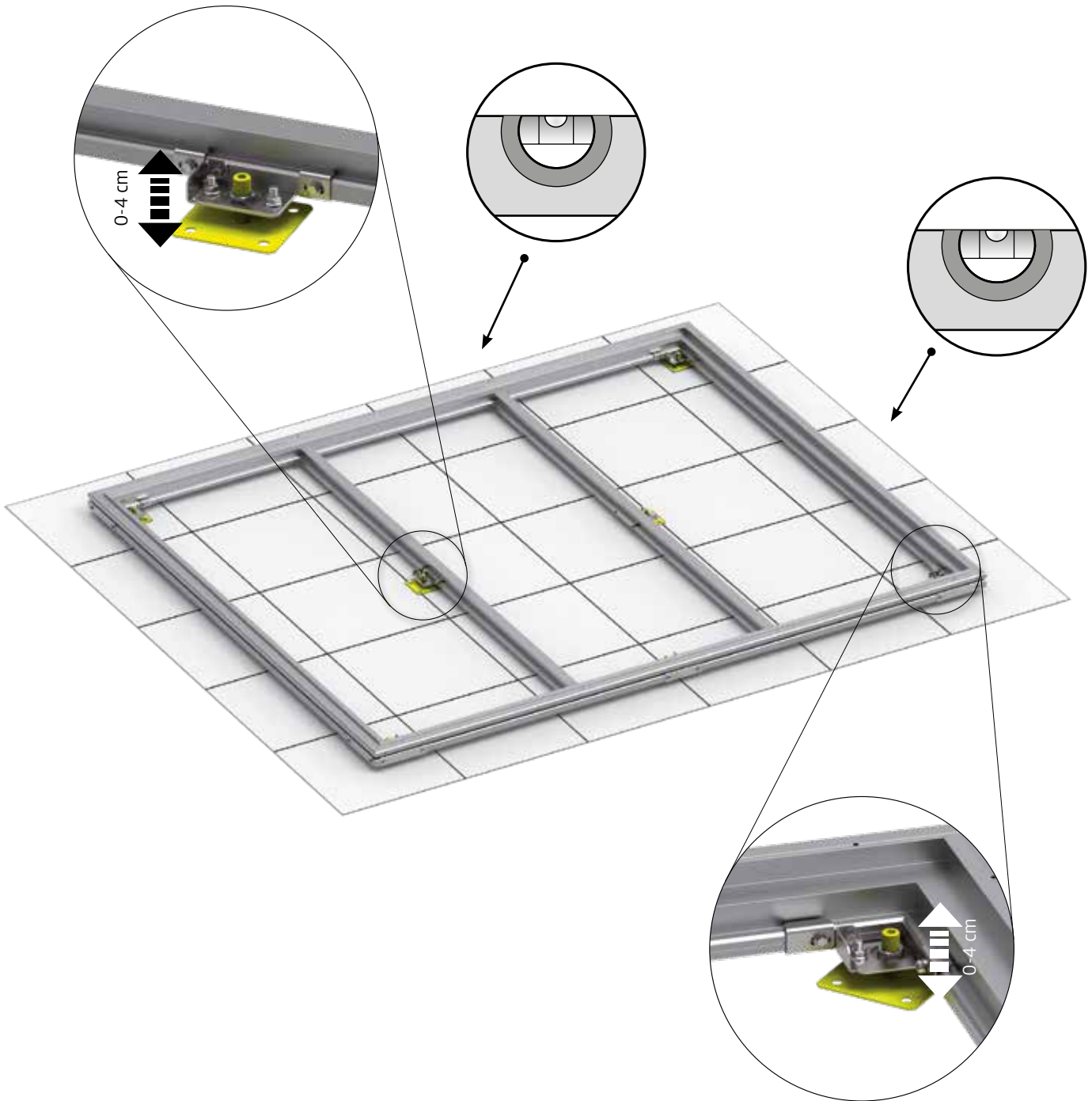

6.

8 x 60



(D1)

Europa

- 1: 8x
- 2: 10x
- 2A: 12x
- 3: 14x

Europa

- 4: 14x
- 4A: 14x
- 5: 16x
- 6: 16x
- 7: 22x

HighLine® Panorama®

- HS: 14x
- 1: 14x
- 2: 14x
- 3: 14x
- 4: 18x
- 5: 22x
- 6: 32x

AvantGarde®

- A1: 12x
- A2: 12x
- A3: 14x
- A4: 18x
- A5: 14x
- A6: 14x
- A7: 18x
- A8: 24x

Geräteschrank

Equipment Locker

Armoire à outils

- 90: 8x
- 150: 8x
- 190: 12x
- 230: 12x
- 150^{LARGE}: 10x
- 190^{LARGE}: 14x
- 230^{LARGE}: 14x

MiniGarage

L: 14x

NEO

- 1A: 12x
- 2A: 14x
- 1B: 14x
- 2B: 14x

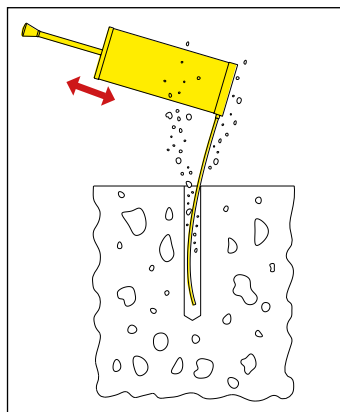
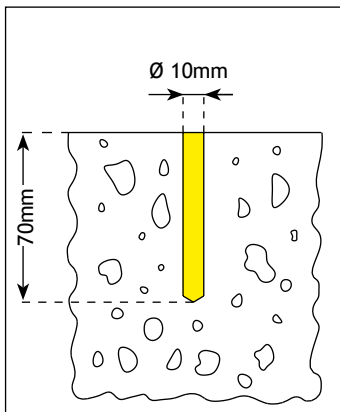
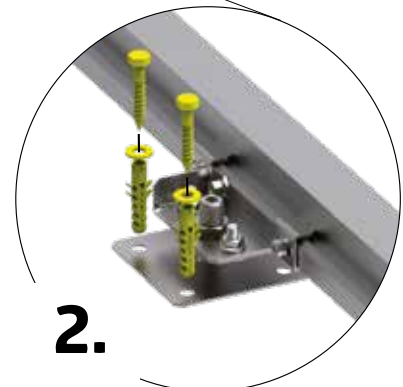
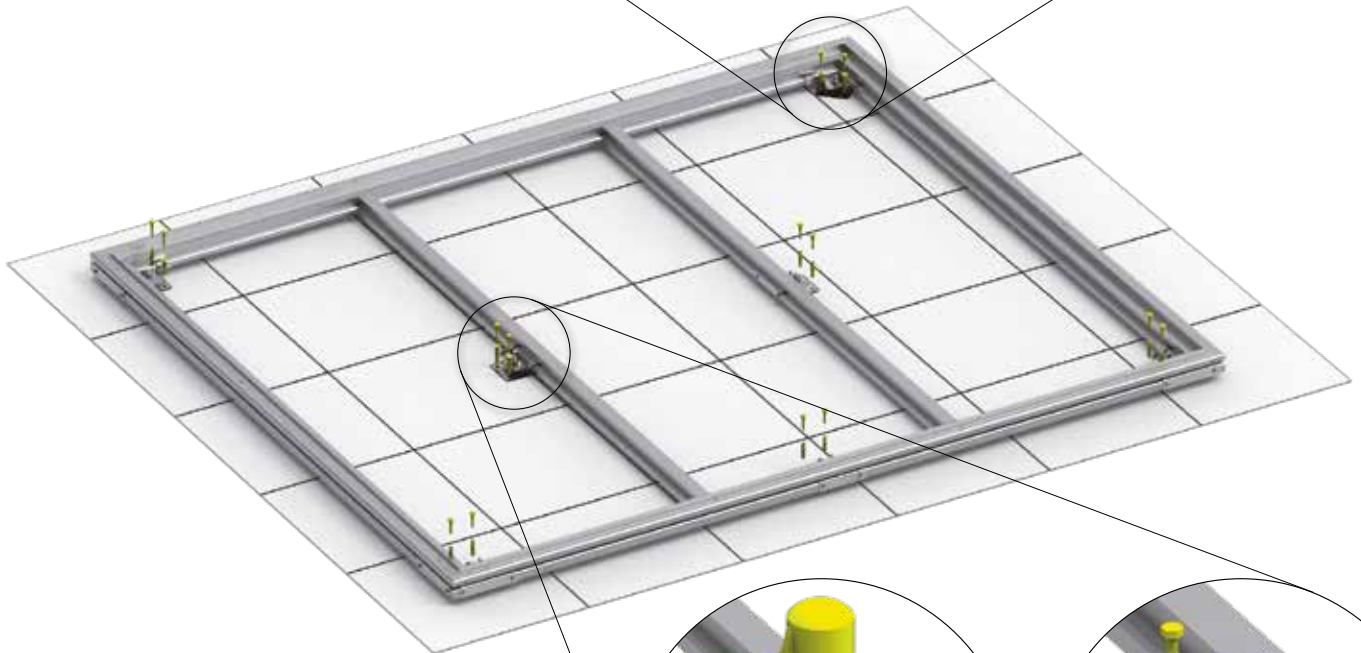
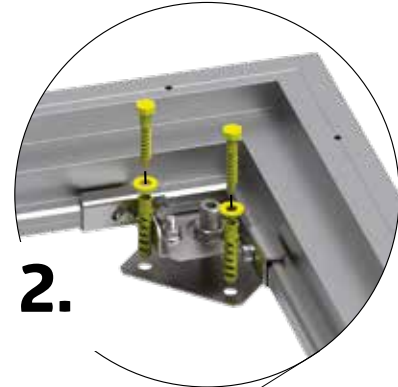
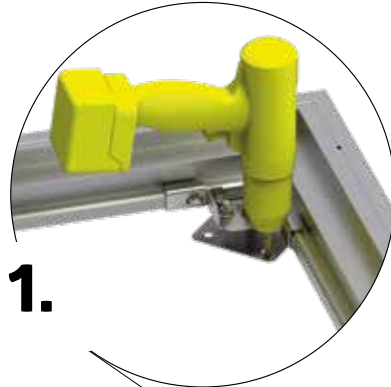

7.

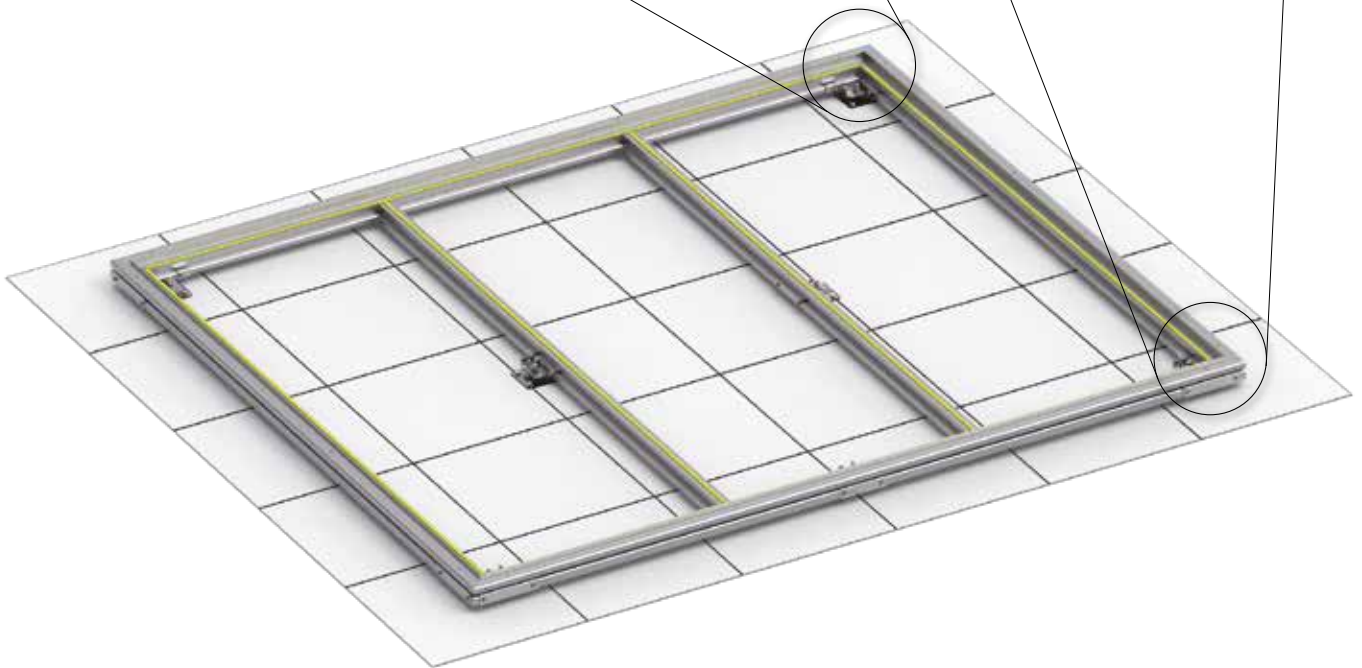
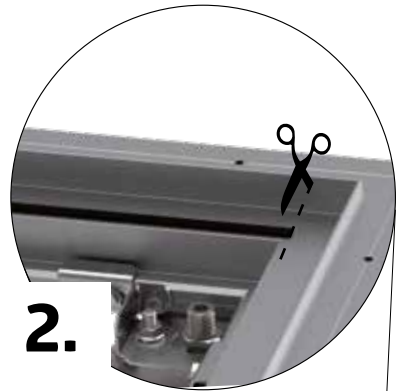
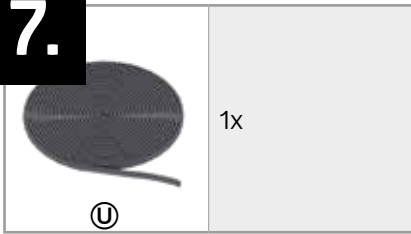

8.



Ⓜ



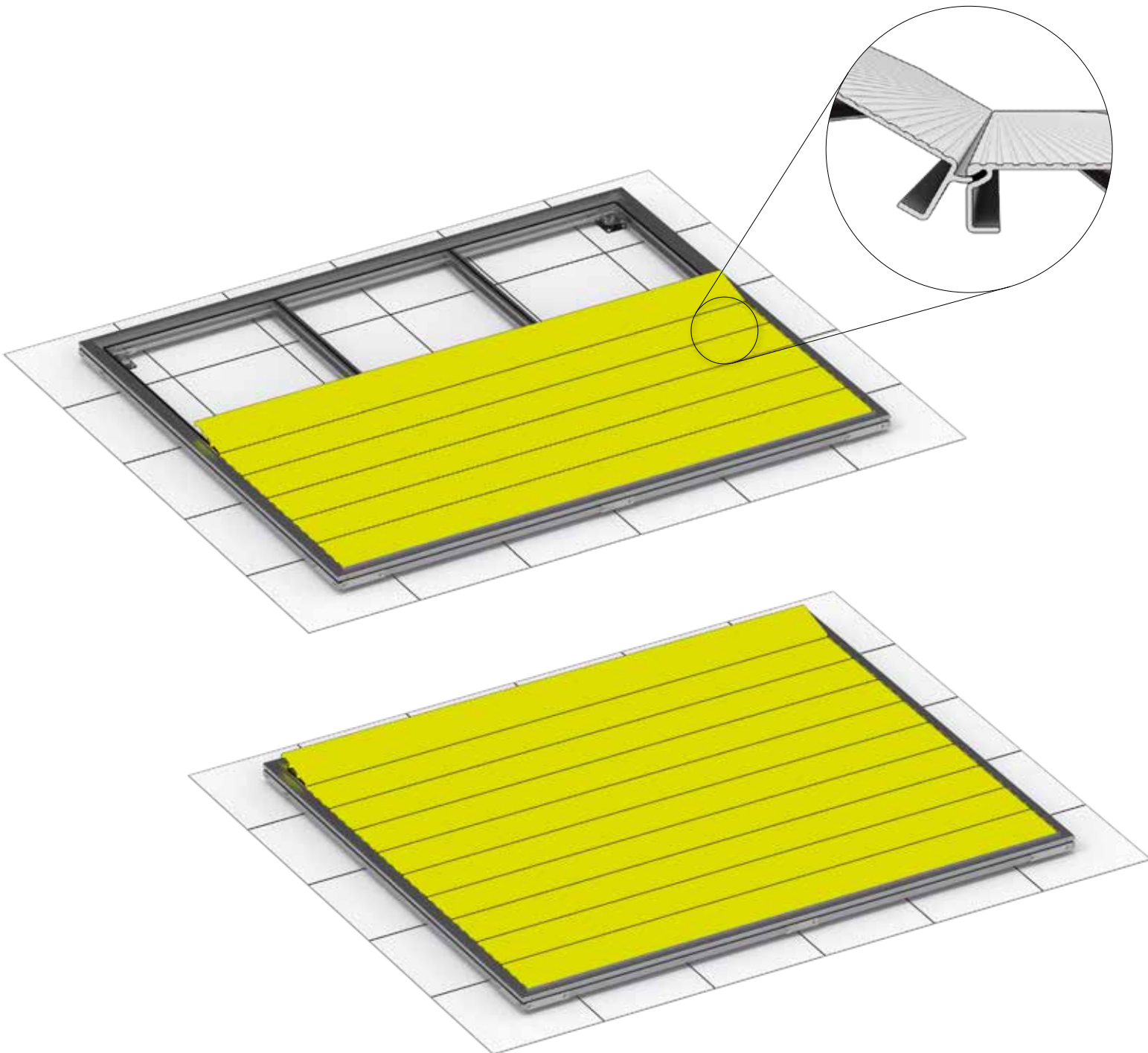

Ⓜ

<p>Europa</p> <p>1: 0X 2: 6X (1400x200mm) 2a: 0X 3: 6X (2120x200mm)</p>	<p>Europa</p> <p>4: 8X (2120x200mm) 4A: 6X (2840x200mm) 5: 8X (2840x200mm) 6: 8X (2840x200mm) 7: 9X (2840x200mm)</p>	<p>HighLine®, Panorama®</p> <p>HS: 6X (2420x200mm) 1: 6X (2420x200mm) 2: 8X (2420x200mm) 3: 10X (2420x200mm) 4: 12X (2420x200mm) 5: 14X (2420x200mm) 6: 14X (2820x200mm)</p>	<p>AvantGarde®</p> <p>A1: 8X (1620x200mm) A2: 10X (1620x200mm) A3: 8X (2420x200mm) A4: 16X (1620x200mm) A5: 8X (2420x200mm) A6: 10X (2420x200mm) A7: 12X (2420x200mm) A8: 16X (2420x200mm)</p>	<p>Geräteschrank Equipment Locker Armoire à outils</p> <p>90: 0X 150: 0X 190: 0X 230: 0X 150^{LARGE}: 6X (1400x200mm) 190^{LARGE}: 7X (1400x200mm) 230^{LARGE}: 6X (2120x200mm)</p>	<p>MiniGarage L: 3X (1880x200mm)</p> <hr/> <p>NEO</p> <p>1A: 6X (1560x200mm) 2A: 6X (2120x200mm) 1B: 6X (2120x200mm) 2B: 8X (2120x200mm)</p>
<p>Europa</p> <p>1: 4X (1400x170mm) 2: 1X (1400x170mm) 2A: 4X (2120x170mm) 3: 1X (2120x170mm)</p>	<p>Europa</p> <p>4: 3X (2120x170mm) 4A: 1X (2840x170mm) 5: 3X (2840x170mm) 6: 3X (2840x170mm) 7: 6X (2840x170mm)</p>	<p>HighLine®, Panorama®</p> <p>HS: 0X 1: 0X 2: 0X 3: 0X 4: 0X 5: 0X 6: 0X</p>	<p>AvantGarde®</p> <p>A1: 0X A2: 0X A3: 0X A4: 0X A5: 0X A6: 0X A7: 0X A8: 0X</p>	<p>Geräteschrank Equipment Locker Armoire à outils</p> <p>90: 4X (780x170mm) 150: 4X (1400x170mm) 190: 4X (1760x170mm) 230: 4X (2120x170mm) 150^{LARGE}: 1X (1400x170mm) 190^{LARGE}: 2X (1400x170mm) 230^{LARGE}: 1X (2120x170mm)</p>	<p>MiniGarage L: 4X (1880x170mm)</p> <hr/> <p>NEO</p> <p>1A: 2X (1560x170mm) 2A: 2X (2120x170mm) 1B: 2X (2120x170mm) 2B: 3X (2120x170mm)</p>

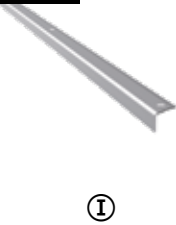

9.

 <p>①</p>	Europa 1: 2X (684mm) 2: 4X (1404mm) 2A: 2X (684mm) 3: 2X (1404mm)	Europa 4: 4X (2124mm) 4A: 2X (1404mm) 5: 2X (2124mm) 6: 2X (2124mm) 7: 4X (2844mm)	HighLine® Panorama® HS: 2X (1224mm) 1: 2X (1224mm) 2: 2X (1624mm) 3: 2X (2024mm) 4: 4X (2424mm) 5: 2X (2424mm) 6: 4X (2824mm)	AvantGarde® A1: 4X (1624mm) A2: 2X (1624mm) A3: 2X (1624mm) A4: 2X (1624mm) A5: 2X (2424mm) A6: 2X (2424mm) A7: 4X (2424mm) A8: 2X (2424mm)	Geräteschrank Equipment Locker Armoire à outils 90: 2X (684mm) 150: 2X (684mm) 190: 2X (684mm) 230: 2X (684mm) 150 ^{LARGE} : 4X(1404mm) 190 ^{LARGE} : 2X(1404mm) 230 ^{LARGE} : 2X(1404mm)	MiniGarage L: 2X (1884mm)
	Europa 1: 2X (1404mm) 2: 0X 2A: 2X (2124mm) 3: 2X (2124mm)	Europa 4: 0X 4A: 2X (2844mm) 5: 2X (2844mm) 6: 2X (2844mm) 7: 0X	HighLine® Panorama® HS: 2X (2424mm) 1: 2X (2424mm) 2: 2X (2424mm) 3: 2X (2424mm) 4: 0X 5: 2X (2824mm) 6: 0X	AvantGarde® A1: 0X A2: 2X (2024mm) A3: 2X (2424mm) A4: 2X (3224mm) A5: 2X (1624mm) A6: 2X (2024mm) A7: 0X A8: 2X (3224mm)	Geräteschrank Equipment Locker Armoire à outils 90: 2X (784mm) 150: 2X (1404mm) 190: 2X (1764mm) 230: 2X (2124mm) 150 ^{LARGE} : 0X 190 ^{LARGE} : 2X(1764mm) 230 ^{LARGE} : 2X(2124mm)	MiniGarage L: 2X (1304mm)
 <p>①</p>	Europa 1: 2X (1404mm) 2: 0X 2A: 2X (2124mm) 3: 2X (2124mm)	Europa 4: 0X 4A: 2X (2844mm) 5: 2X (2844mm) 6: 2X (2844mm) 7: 0X	HighLine® Panorama® HS: 2X (2424mm) 1: 2X (2424mm) 2: 2X (2424mm) 3: 2X (2424mm) 4: 0X 5: 2X (2824mm) 6: 0X	AvantGarde® A1: 0X A2: 2X (2024mm) A3: 2X (2424mm) A4: 2X (3224mm) A5: 2X (1624mm) A6: 2X (2024mm) A7: 0X A8: 2X (3224mm)	Geräteschrank Equipment Locker Armoire à outils 90: 2X (784mm) 150: 2X (1404mm) 190: 2X (1764mm) 230: 2X (2124mm) 150 ^{LARGE} : 0X 190 ^{LARGE} : 2X(1764mm) 230 ^{LARGE} : 2X(2124mm)	MiniGarage L: 2X (1304mm)
	Europa 1: 2X (1404mm) 2: 0X 2A: 2X (2124mm) 3: 2X (2124mm)	Europa 4: 0X 4A: 2X (2844mm) 5: 2X (2844mm) 6: 2X (2844mm) 7: 0X	HighLine® Panorama® HS: 2X (2424mm) 1: 2X (2424mm) 2: 2X (2424mm) 3: 2X (2424mm) 4: 0X 5: 2X (2824mm) 6: 0X	AvantGarde® A1: 0X A2: 2X (2024mm) A3: 2X (2424mm) A4: 2X (3224mm) A5: 2X (1624mm) A6: 2X (2024mm) A7: 0X A8: 2X (3224mm)	Geräteschrank Equipment Locker Armoire à outils 90: 2X (784mm) 150: 2X (1404mm) 190: 2X (1764mm) 230: 2X (2124mm) 150 ^{LARGE} : 0X 190 ^{LARGE} : 2X(1764mm) 230 ^{LARGE} : 2X(2124mm)	MiniGarage L: 2X (1304mm)

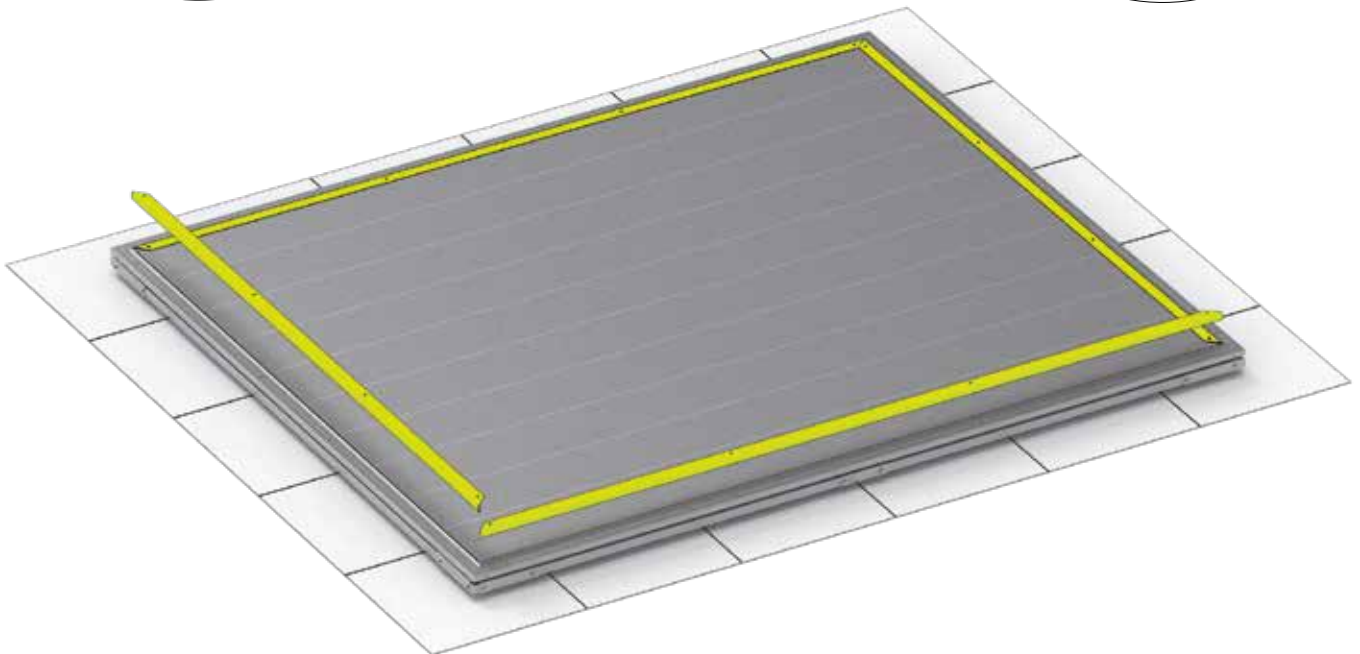
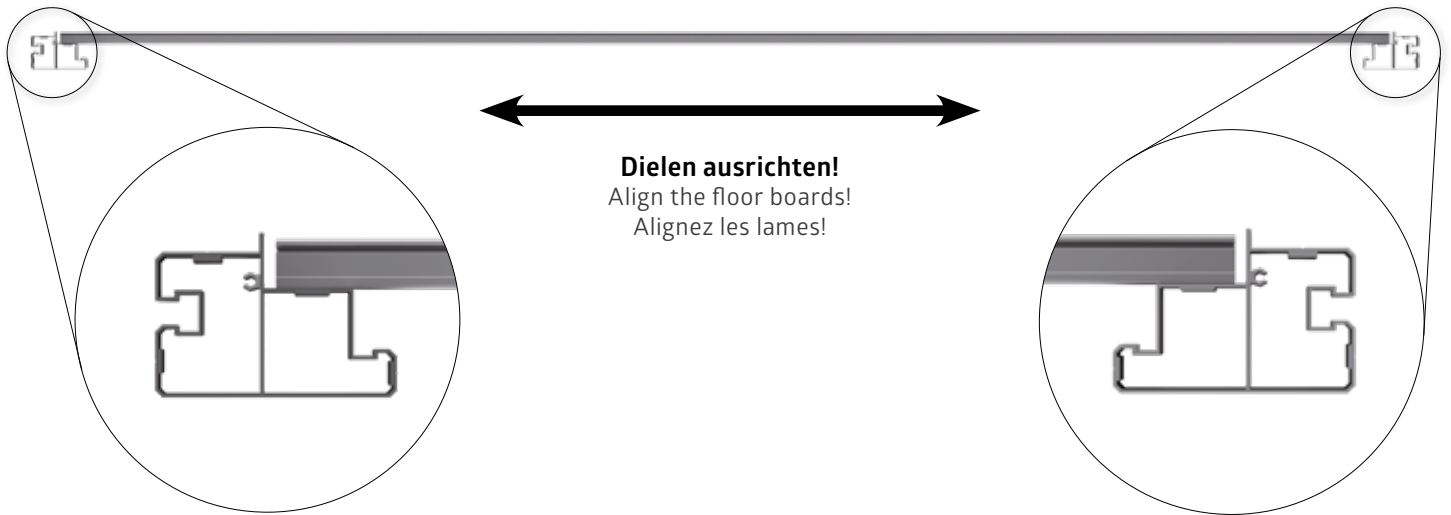

10.

4,8 x 45



D1

Europa

- 1: 12x
- 2: 16x
- 2A: 12x
- 3: 16x

Europa

- 4: 16x
- 4A: 20x
- 5: 20x
- 6: 20x
- 7: 24x

HighLine® Panorama®

- HS: 16x
- 1: 16x
- 2: 16x
- 3: 16x
- 4: 16x
- 5: 20x
- 6: 24x

AvantGarde®

- A1: 16x
- A2: 16x
- A3: 16x
- A4: 20x
- A5: 16x
- A6: 16x
- A7: 16x
- A8: 20x

Geräteschrank

Equipment Locker
Armoire à outils

- 90: 8x
- 150: 12x
- 190: 12x
- 230: 12x
- 150^{LARGE}: 16x
- 190^{LARGE}: 16x
- 230^{LARGE}: 16x

MiniGarage

L: 14x

NEO

- 1A: 12x
- 2A: 14x
- 1B: 14x
- 2B: 16x

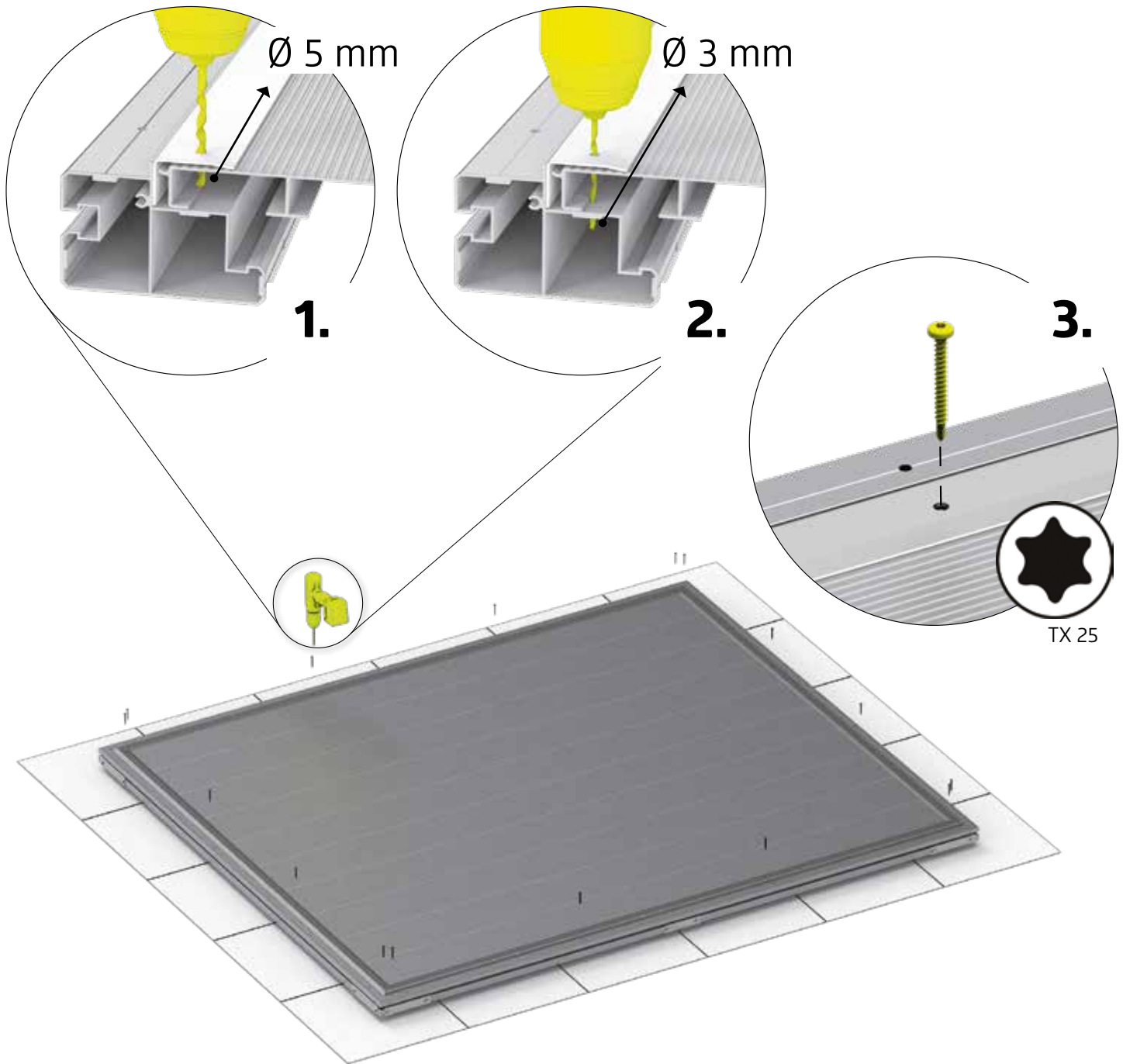

Ø 5 mm

1.

Ø 3 mm

2.

3.

TX 25

11.

<p>22 x 2</p>  <p>(D1)</p>	<p>Europa</p> <p>1: 14x 2: 20x 2A: 14x 3: 20x</p>	<p>Europa</p> <p>4: 20x 4A: 20x 5: 20x 6: 20x 7: 20x</p>	<p>HighLine® Panorama®</p> <p>HS: 14x 1: 14x 2: 18x 3: 16x 4: 16x 5: 18x 6: 24x</p>	<p>AvantGarde®</p> <p>A1: 20x A2: 18x A3: 18x A4: 20x A5: 18x A6: 16x A7: 16x A8: 20x</p>	<p>Geräteschrank Equipment Locker Armoire à outils</p> <p>90: 8x 150: 14x 190: 10x 230: 14x 150^{LARGE}: 20x 190^{LARGE}: 16x 230^{LARGE}: 20x</p>	<p>MiniGarage L: 14x</p> <p>NEO</p> <p>1A: 0x 2A: 0x 1B: 0x 2B: 0x</p>
<p>6,3 x 22 *</p>  <p>(D1)</p>	<p>Europa</p> <p>1: 14x 2: 20x 2A: 14x 3: 20x</p>	<p>Europa</p> <p>4: 20x 4A: 20x 5: 20x 6: 20x 7: 20x</p>	<p>HighLine® Panorama®</p> <p>HS: 14x 1: 14x 2: 18x 3: 16x 4: 16x 5: 18x 6: 24x</p>	<p>AvantGarde®</p> <p>A1: 20x A2: 18x A3: 18x A4: 20x A5: 18x A6: 16x A7: 16x A8: 20x</p>	<p>Geräteschrank Equipment Locker Armoire à outils</p> <p>90: 8x 150: 14x 190: 10x 230: 14x 150^{LARGE}: 20x 190^{LARGE}: 16x 230^{LARGE}: 20x</p>	<p>MiniGarage L: 14x</p> <p>NEO</p> <p>1A: 16x 2A: 14x 1B: 14x 2B: 12x</p>

*Selbstschneidende Schraube
Self-tapping screw - Vis autotaraudeuse

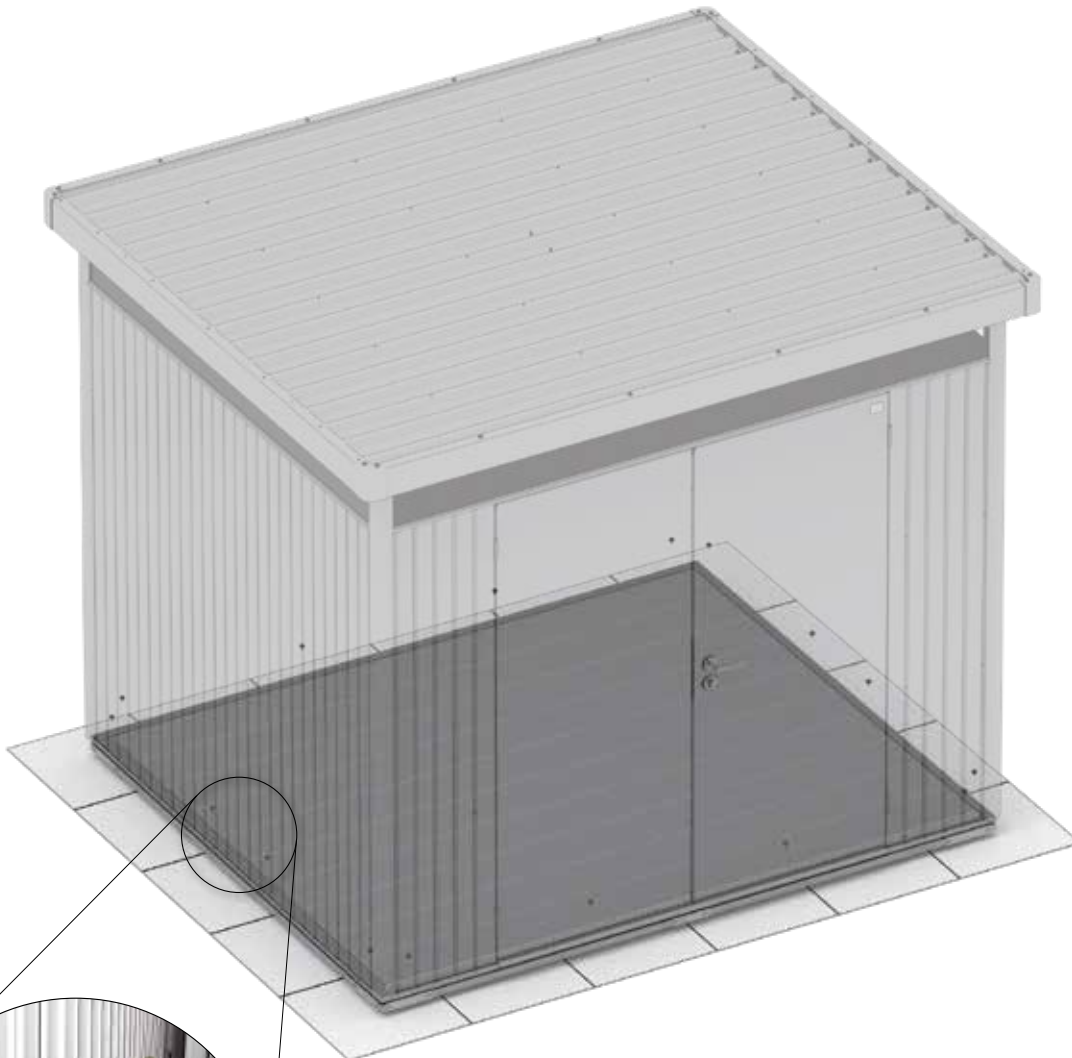



GERÄTEHÄUSER – Setzen Sie auf Qualität & Langlebigkeit
GARDEN SHEDS – rely on quality & longevity



GARTENBOXEN – Outdoorboxen für Garten, Terrasse & Co.
OUTDOOR BOXES – outdoor boxes for garden, patio & etc.



FAHRRAD-GARAGEN – Fahrräder, Roller & Co. sicher verstaut
BICYCLE STORAGE – bicycles, scooters & etc. safely stowed



MÜLLTONNEN-BOXEN – Stylish, praktisch & wartungsfrei
DUSTBIN STORAGE – stylish, practical & maintenance free



GARTEN-HELPER – Gartendesign in Bestform
GARDENING HELPERS – garden design at its best



Biohort steht für
„LEBEN IM GARTEN“

Biohort stands for
„LIFE IN THE GARDEN“

follow us:

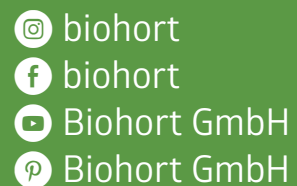

Biohort GmbH
 Pürnstein 43, 4120 Neufelden, Österreich
 +43 7282 / 7788 0
 E-Mail: office@biohort.at
 www.biohort.com



Adresses sur quefairedemesdechets.fr