

STÜCKLISTE

„SmartBase Plus“ NEO

Stand Juli 2024 | technische Änderungen vorbehalten



1 ERDSCHRAUBEN - PAKET

Erdschrauben - Paket · Ground screw package · Carton de vis de fondation · Grondschroefpakket · Paquete de láminas · Pacco viti di ancoraggio a terra · Jordskruepakke

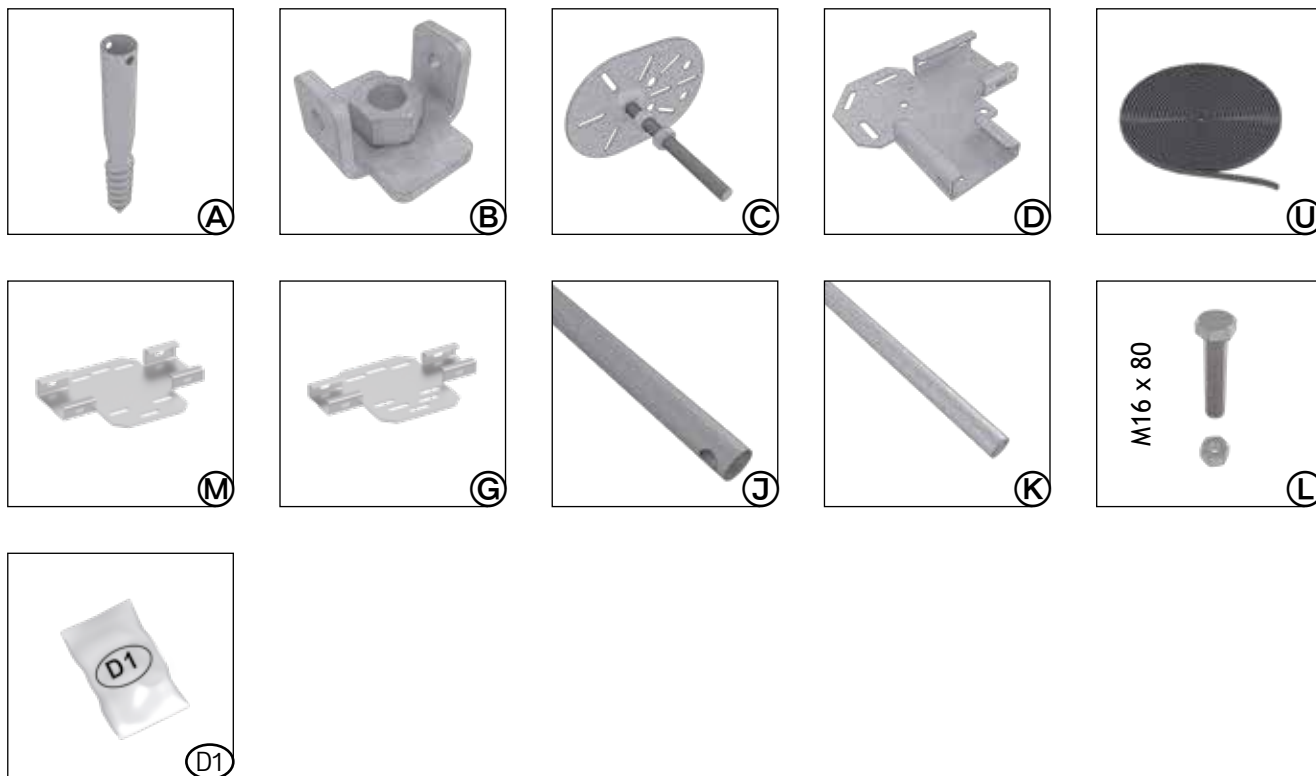

2 PROFIL - PAKET

Profile package · Carton de profils · Profelpaket · Kit de perfiles · Pacco profili · Profilpakke · Profilpaket · Profilpakke · opakowanie zawierające elementy profilowe · Balenie profilov · Profilni paket · Balení profilů · Profilsomag · Paket profila

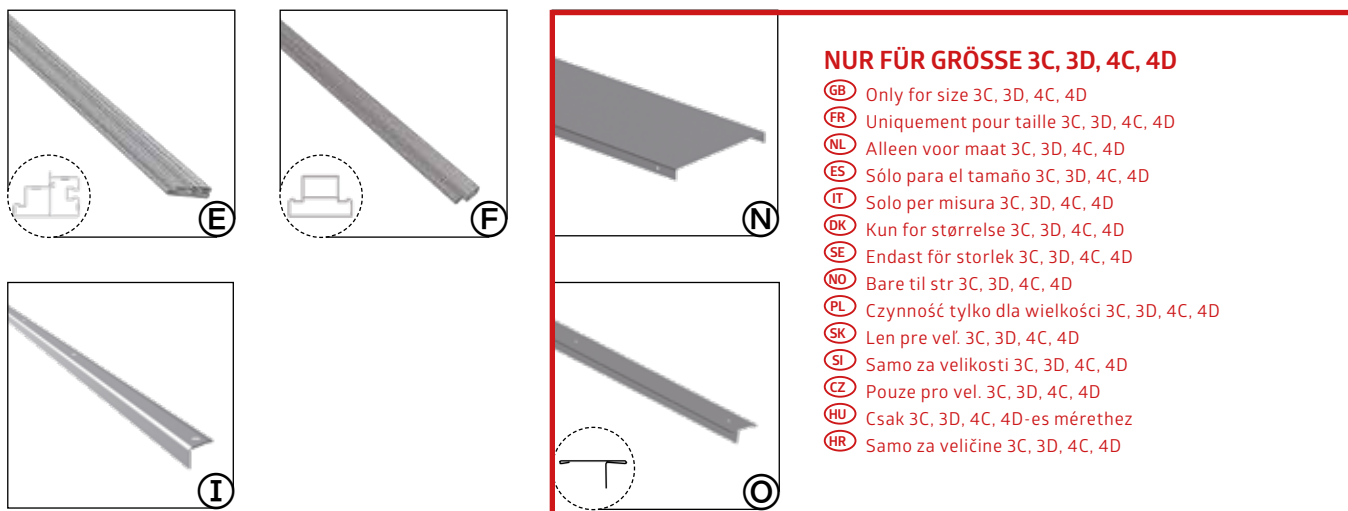

NUR FÜR GRÖSSE 3C, 3D, 4C, 4D

- GB** Only for size 3C, 3D, 4C, 4D
- FR** Uniquement pour taille 3C, 3D, 4C, 4D
- NL** Alleen voor maat 3C, 3D, 4C, 4D
- ES** Sólo para el tamaño 3C, 3D, 4C, 4D
- IT** Solo per misura 3C, 3D, 4C, 4D
- DK** Kun for størrelse 3C, 3D, 4C, 4D
- SE** Endast för storlek 3C, 3D, 4C, 4D
- NO** Bare til str 3C, 3D, 4C, 4D
- PL** Czynność tylko dla wielkości 3C, 3D, 4C, 4D
- SK** Len pre veľ. 3C, 3D, 4C, 4D
- SI** Samo za velikosti 3C, 3D, 4C, 4D
- CZ** Pouze pro vel. 3C, 3D, 4C, 4D
- HU** Csak 3C, 3D, 4C, 4D-es mérethez
- HR** Samo za veličine 3C, 3D, 4C, 4D

DIELN - PAKET

Floorboards package · Colis de lames · Plankenpaket · Pacco tavole per pavimento · Paquete de tablas de suelo · Gulvpakke · Plankpaket · Gulvpanel pakke · Opakowanie zawierające panele podłogowe · Balenie podlahových dosiek · Paket talnih desk · Balení podlahových desek · Deszka csomag · Paket podnih dasaka

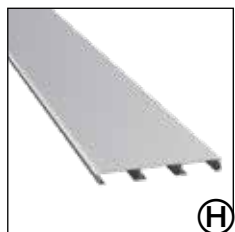



Paket Nr.	Pos.-Nr.	Artikel-Nummer	Maße (mm)	Artikelname	1A	1B/2A	2B	1C/3A	1D/4A	2C/3B	2D/4B	3C	3D/4C	4D
					Stk.	Stk.	Stk.	Stk.	Stk.	Stk.	Stk.	Stk.	Stk.	Stk.
Paket Nr. 1 Erdschraubenpaket	A	XF703700	/	Erdschraube	6	7	7	11	7+6	6+10	10+8	6+10	6+10	10+8
	B	XF700711	/	Gewindeinsatz dm 60	6	7	7	11	7+6	6+10	10+8	6+10	6+10	10+8
	C	XF700720	/	Adapterplatte	6	7	7	11	7+6	6+10	10+8	6+10	6+10	10+8
	D	XF700701	/	Eckverbinder	4	4	4	4	4	4	4	4	4	4
	G	XF700702	/	Befestigungswinkel	3	5	5	-	-	-	-	-	-	-
	G	XF700707	/	Verbinder Strebe	-	-	-	3	3	6	6	6	6	6
		XF700713		Set für Eindreh- und Hebelstange	1	1	1	1	1	1	1	1	1	1
	J	XF700714	/	Eindrehstange	1	1	1	1	1	1	1	1	1	1
	K	XF700715	/	Hebelstange	1	1	1	1	1	1	1	1	1	1
	L	A4003034	/	Sechskantschraube M16x80 mm	1	1	1	1	1	1	1	1	1	1
	A2000034	/	Mutter M16	1	1	1	1	1	1	1	1	1	1	
M	XF700708	/	Verbinder Fundament Erdschraube	-	-	-	4	6	2+4	4+4	2+4	2+4	4+4	
U	X0001007	20	Vorlegeband	1	1	1	1	1	1	1	1	1	1	
D1	XF700553	/	Schraubenpaket	1	1	1	1	1	1	1	1	1	1	
	XF700559	/	Schraubenpaket Zusatz	-	-	-	-	-	1	1	1	1	1	
	XF700560	/	Schraubenpaket Zusatz 1D/4A	-	-	-	-	-	1	-	-	-	-	
	YF043000		Aufbauanleitung	1	1	1	-	-	-	-	-	-	-	
	YF043010		Aufbauanleitung	-	-	-	1	1	1	1	1	1	1	

Paket Nr.	Pos.-Nr.	Artikel-Nummer	Maße (mm)	Artikelname	1A	1B/2A	2B	1C/3A	1D/4A	2C/3B	2D/4B	3C	3D/4C	4D
					Stk.	Stk.	Stk.	Stk.	Stk.	Stk.	Stk.	Stk.	Stk.	Stk.
Paket Nr. 2 Profilpaket	E	XF700614	1660	Fundamentprofil	4	2	-	2	2	-	-	-	-	-
		XF700606	2220	Fundamentprofil	-	2	4	-	-	2	2	-	-	-
		XF700615	1390	Fundamentprofil rechts	-	-	-	2	-	2	-	-	2x2	2x1
		XF700616	1390	Fundamentprofil links	-	-	-	2	-	2	-	-	2x2	2x1
		XF700617	1670	Fundamentprofil rechts	-	-	-	-	2	-	2	-	-	2x1
		XF700618	1670	Fundamentprofil links	-	-	-	-	2	-	2	-	-	2x1
	F	XF700642	1494			1	2	-	-	-	-	-	-	-
		XF700633	2054		Fundamentstrebe	-	-	2	-	-	-	-	-	-
		XF700619	1307			-	-	-	2	-	4	-	2x4	2x4
		XF700620	1587			-	-	-	-	2	-	4	-	2x4
I	XF700684	1564	Abschlussleiste	4	2	-	2	2	-	-	-	-	-	
	XF700677	2124	Abschlussleiste	-	2	4	-	-	2	2	-	-	-	
	XF700685	1342	Abschlussleiste links	-	-	-	2	-	2	-	-	4	2x1	
	XF700686	1342	Abschlussleiste rechts	-	-	-	2	-	2	-	-	4	2x1	
	XF700687	1622	Abschlussleiste links	-	-	-	-	2	-	2	-	-	2x1	
	XF700688	1622	Abschlussleiste rechts	-	-	-	-	2	-	2	-	-	2x1	
O	XF700691	1305	Abschlussleiste mitte	-	-	-	-	-	-	-	-	2x1	2x1	
	XF700692	1585		-	-	-	-	-	-	-	-	-	2x1	
N	XF700733	1289	Trägerversteifung	-	-	-	-	-	-	-	-	2x1	2x1	
	XF700734	1569		-	-	-	-	-	-	-	-	-	2x1	

Paket Nr.	Pos.-Nr.	Artikel-Nummer	Maße (mm)	Artikelname	1A	1B/2A	2B	1C/3A	1D/4A	2C/3B	2D/4B	3C	3D/4C	4D	
Dielenpaket 43449 (1A/1D/4A) 43448 (1B/2D/4B) 43429 (2B) 43435 (2B/2C/2D/3B/4B) 43403 + 43903 (1C/3A) 43409 + 43909 (1D/4A) 43415 (2C/3B) 43416 (2D/4B) 2x 43420 + 2x 43920 (3C) 2x 43980 (3D/4C) 2x 43480 (3D/4C/4D) 2x 43471 + 43484 (4D)	H	XF700662	1560 x 170	Bodendielen	2	-	-	4+7	2+4	-	-	-	-	-	
		XF700663	1560 x 200		6	-	-	4	5+6	-	-	-	-	-	-
		XF700655	2120 x 170		-	2	1+2	-	7+2	2+2+2	-	-	-	-	-
		XF700656	2120 x 200		-	6	6+2	-	2	3+2+6	-	-	-	-	-
		XF700665	1340 x 170		-	-	-	-	-	-	-	-	8+14	-	-
		XF700664	1340 x 200		-	-	-	-	-	-	-	-	8	-	-
		XF700667	1620 x 170		-	-	-	-	-	-	-	-	-	14+8	14+4
		XF700654	1620 x 200		-	-	-	-	-	-	-	-	-	2+6	2+16

Paket Nr.	Artikel-Nummer	Artikelname	Stk.
D1 Schraubepaket XF700553 	A51016	Sechskantschraube 8 x 16 mm	25
	A4005014	Beilagscheibe DM 8,4 x 24x	25
	A4002022	Torbandschraube M8 x 20 mm verzinkt	35
	A4003033	Sperrzahnmutter mit Flansch M8 vz	35
	A4003032	Sechskantbohrschraube 6.3x22, vz	75
	A4005010	Beilagscheibe 6,6 x 22 x 2 mm	25
	A4003036	Linseblechschraube, 4.8x45 mm TX 25	25
	A4003035	Linseblechschraube, 4.8x60 mm TX 25	4
	XF700716	Steckschlüssel-Einsatz SW10	1

Paket Nr.	Artikel-Nummer	Artikelname	Stk.
Schraubepaket Zusatz SmartBase Plus XF700559 	A51016	Sechskantschraube 8 x 16 mm	16
	A4005014	Beilagscheibe DM 8,4 x 24x	16
	A4002022	Torbandschraube M8 x 20 mm verzinkt	23
	A4003033	Sperrzahnmutter mit Flansch M8 vz	23
	A4003032	Sechskantbohrschraube 6.3x22, vz	41
	A4003036	Linseblechschraube, 4.8x45 mm TX 25	6

Paket Nr.	Artikel-Nummer	Artikelname	Stk.
Schraubepaket Zusatzpaket 1D/4A XF700560 	A51016	Sechskantschraube 8 x 16 mm	2
	A4005014	Beilagscheibe DM 8,4 x 24x	2
	A4003032	Sechskantbohrschraube 6.3x22, vz	4

Hinweis: Alle Art.Nr. mit XF waren vorher XT